

AIRMAN

PC

INSTRUCTION MANUAL

ENGINE COMPRESSOR

PDS185S-6EZ1

Please be sure to read this manual
before using this machine.

HOKUETSU INDUSTRIES CO., LTD.

Preface / Table of Contents

Thank you for having selected our "AIRMAN" product.

- ◆ Keep this manual at hand to refer to it always when necessary.
- ◆ When this manual is missing or damaged, order it from our office nearby or distributor. Make sure that the manual is included with the machine when it is handed over to another user.
- ◆ The contents of this manual may differ from the machine because of design changes. If anything is unclear, please contact our office or your nearest dealer for clarification.
- ◆ For details of handling, maintenance and safety of the engine, see the Engine Operation Manual.

— Table of Contents —



1. Part Names	1-1
1.1 Internal Components and Part Names	1-1
2. Installation	2-1
2.1 Transportation	2-1
2.2 Towing the Machine	2-2
2.3 Installation conditions	2-3
3. Operation	3-1
3.1 Instrument Panel	3-1
3.2 Lubricating oil · Coolant · Fuel	3-2
3.3 Check before starting unit	3-4
3.4 Operating Procedure	3-11
4. Failure cause and measures	4-1
4.1 Indicator lamp and Warning / Emergency display	4-1
4.2 Troubleshooting	4-3
5. Periodic Inspection/Maintenance	5-1
5.1 Important Items as Periodic Inspection and Maintenance or after Maintenance	5-1
5.2 Inspection on Separator Receiver Tank	5-2
5.3 Periodic Inspection List	5-3
5.4 Replacement Parts Schedule	5-5
5.5 Maintenance Items	5-6
6. Storage and Disposal	6-1
6.1 Preparation for Long-term Storage	6-1
6.2 Disposal of Product	6-1
7. Specifications	7-1
7.1 Specifications	7-1
7.2 Exterior drawing	7-2
7.3 Wiring Diagram	7-4
7.4 Piping Diagram	7-5

Safety

This section explains safety cautions for safety work for operation, inspection, maintenance, installation, movement and transportation. Read these safety requirements carefully and fully understand the contents before starting the machine.

For your better understanding of the precautions in this manual and on this machine, safety precautions are classified into “DANGER”, “WARNING” and “CAUTION” message with a warning symbol  marked, according to the degree of hazards.

When one of these messages is found, please take preventative safety measures and carry out “SAFETY OPERATION AND PROPER MAINTENANCE OF THE MACHINE”.

 DANGER	DANGER indicates an imminently hazardous situation which, if not avoided, will result in death or serious injury.
 WARNING	WARNING indicates a potentially hazardous situation which, if not avoided, could result in death or serious injury.
 CAUTION	CAUTION indicates a potentially hazardous situation which, if not avoided, may result in minor or moderate injury. It may also be used to alert against unsafe practices.
IMPORTANT	IMPORTANT indicates important caution messages for the performance or durability of the machine, which has no concern to injury or accident of or to a human body.

This manual does not describe all safety items. We, therefore, advise you to pay special attention to all items (even though they may not be described in the manual) for your safety.

PROPOSITION 65 WARNING

 WARNING
<p>Breathing engine exhaust exposes you to chemicals known to the State of California to cause cancer and birth defects or other reproductive harm.</p> <ul style="list-style-type: none"> ● Always start and operate the engine in a well-ventilated area. ● If in an enclosed area, vent the exhaust system. ● Do not modify or tamper with the exhaust system. ● Do not idle the engine except as necessary <p>For more information, go to www.P65warnings.ca.gov/diesel</p>

Safety

- ◆ Please tell us a MODEL /SER.No. on the plate of the machine when you make an inquiry.
A plate stamped with the model and serial number is attached to side of the machine.

PORTABLE COMPRESSOR	
MODEL	<input type="text"/>
SER. NO.	<input type="text"/>
NORMAL OPERATING PRESSURE	<input type="text"/> MPa
NET DRY MASS	<input type="text"/> kg
OPERATING MASS	<input type="text"/> kg
HOKUETSU INDUSTRIES CO., LTD. MADE IN JAPAN 39103 10811	

※ Each illustrated figure (Fig.) has a number (for instance, A130375) at the right bottom. This number is not a part number, it is an internal reference number.

A130375

Safety

[Safety Warning Labels]

Following labels are attached to the machine.

Keep them clean at all times. If they are damaged or missing, immediately place an order with your nearest dealer for replacement. Part numbers are indicated on the lower right corner of the label. Adhere a new one to the original location.

<p>1</p>  <p>▲ DANGER</p> <p>DO NOT BREATHE COMPRESSED AIR</p> <p>Do not use this compressed air for breathing air because it can cause fatal accidents. Never breathe it.</p> <p>39176 73600</p>	<p>2</p>  <p>▲ WARNING</p> <p>BEWARE OF EXHAUST GASES</p> <p>When you operate machine INDOORS or in TUNNEL, provide good ventilation. Poor ventilation can cause fatal accident.</p> <p>39176 73300</p>	<p>3</p>  <p>▲ WARNING</p> <p>BEWARE OF RESIDUAL PRESSURE</p> <p>Release residual pressure inside pipings and hoses and then disconnect them. Disconnection with residual pressure still left can cause serious injury.</p> <p>39176 73400</p>	<p>4</p>  <p>▲ CAUTION</p> <p>PREVENT BURNING ACCIDENT</p> <p>Do not open radiator cap while it is still hot.</p> <p>39176 69600</p>	<p>5</p>  <p>▲ CAUTION</p> <p>PREVENT BURNING ACCIDENT</p> <p>When work is required near hot parts, wait for the parts to cool down fully before starting work.</p> <p>39176 69500</p>
<p>6</p>  <p>▲ WARNING</p> <p>BEWARE OF HIGH PRESSURE AIR BLOW OUT</p> <p>Oil supply and/or maintenance jobs with residual pressure left in tank are very dangerous. So release the residual pressure first.</p> <p>39176 69800</p>	<p>7</p>  <p>▲ CAUTION</p> <p>PREVENT FIRE ACCIDENT</p> <p>Periodically check compressor oil and oil separator surely. Failure of this maintenance can cause fire accident.</p> <p>39176 69700</p>	<p>8</p>  <p>▲ WARNING</p> <p>BEWARE OF ENTANGLEMENT</p> <p>Keep your hands AWAY from fan during operation. Entanglement in the fan can cause serious injury.</p> <p>39176 73500</p>	<p>9</p>  <p>▲ WARNING</p> <p>BEWARE OF ENTANGLEMENT</p> <p>Keep your hands AWAY from moving parts such as V-belts, pulleys etc.. Entanglement in them can cause serious injury.</p> <p>39176 73800</p>	<p>10</p>  <p>LIFTING BAIL</p> <p>39176 69300</p>
<p>11</p>  <p>FLAMMABLES</p> <p>D DIESEL FUEL</p> <p>EPA REGULATION</p> <p>ULTRA LOW SULFUR FUEL ONLY.</p> <p>DIESEL A TRÈS FAIBLE TENEUR EN SOUFRE UNIQUÈMENT.</p> <p>39178 22031</p>	<p>12</p>  <p>▲ CAUTION</p> <p>TOW MACHINE LEVEL TO ELIMINATE POSSIBLE STRESS OF COMPRESSOR FRAME STRUCTURE</p> <p>39178 37310</p>	<p>13</p> <p>DANGER EXPLOSIVE GASES</p> <p>Cigarettes, flames or sparks could cause battery to explode. Always shield eyes and face from battery. Do not charge or use booster cables or adjust post connections without proper instruction and training.</p> <p>KEEP VENT CAPS TIGHT AND LEVEL</p> <p>POISON CAUSES SEVERE BURNS</p> <p>Contains sulfuric acid. Avoid contact with skin, eyes or clothing. In event of accident flush with water and call a physician immediately.</p> <p>KEEP OUT OF REACH OF CHILDREN</p> <p>39176 50000</p>		

Safety

- The pasting position of safety warning labels is as follows.

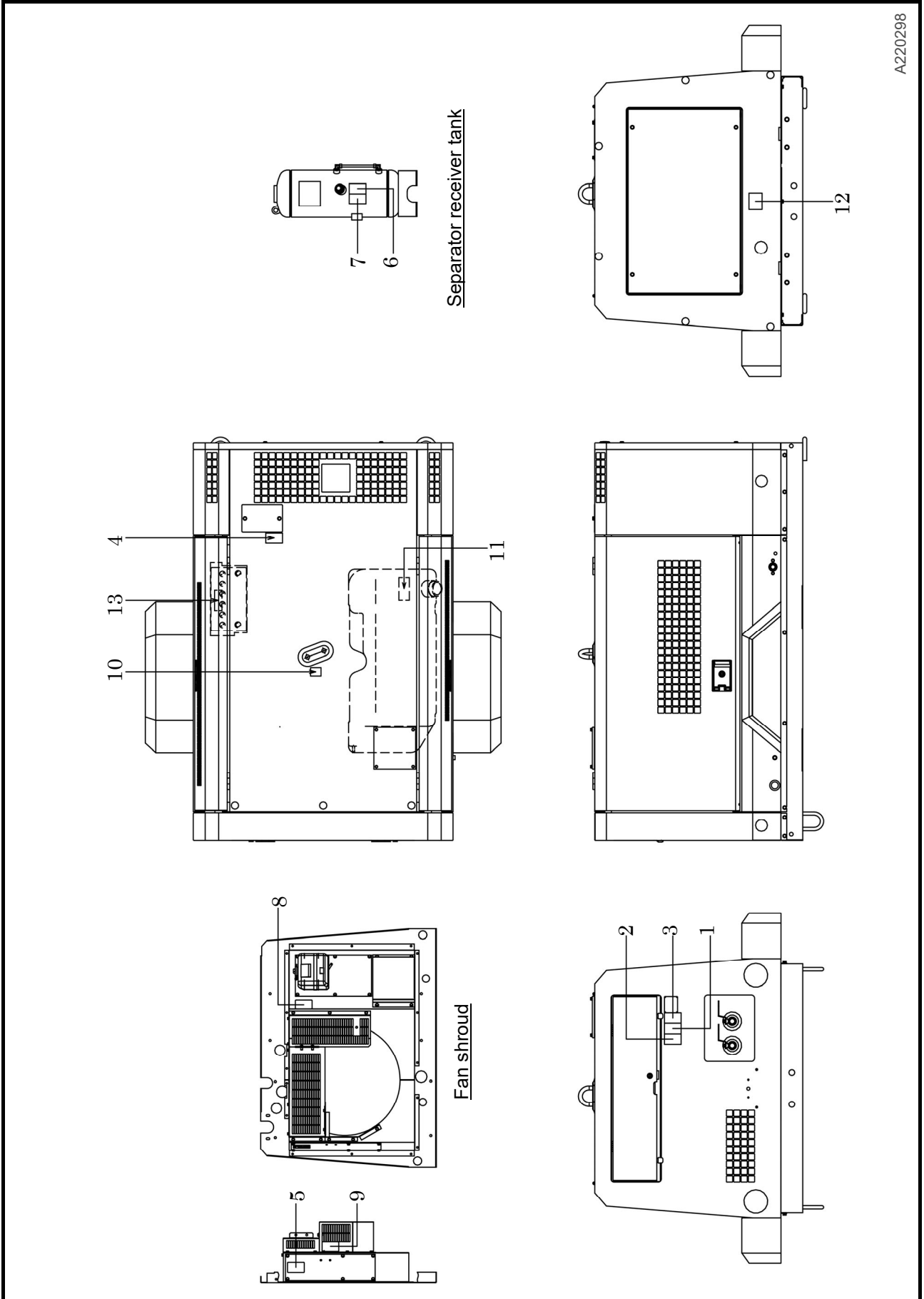

Safety

DANGER

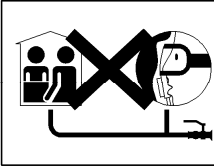

TR0201-1

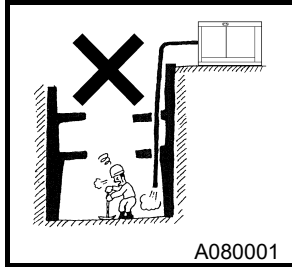

A080001

- Compressed air from this machine contains poisonous materials. Absorption of the compressed air can cause serious injury. Never provide this compressed air for human respiration.
- This machine is not designed to be used for working chambers pressurized by compressed air such as respiratory air provided to persons working inside wells and tunnels such as pneumatic engineering method and pneumatic caisson method. Should this machine stop operation due to trouble, it can cause death and serious injury to the working persons. Refrain from using the compressed air for such pneumatic engineering method or pneumatic caisson method.

WARNING

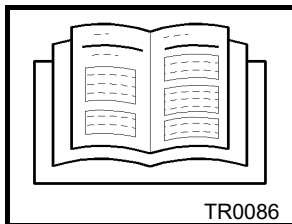

TR0086

- Read each instruction plate which is displayed in the manual or on the machine carefully, understand its content and follow the indications thereof.
- Do not modify the machine without prior approval. The safety may be compromised, functions may be deteriorated, or the machine life may be shortened.
- Never use the machine for the purpose of compression of gases other than air, or as a vacuum pump. Otherwise, serious accidents may occur.

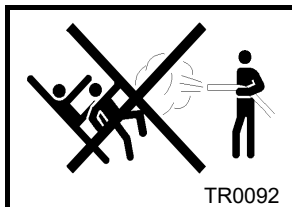

TR0092

- Never blow compressed air directly at people. Scattered impurities, dust, or foreign objects in the compressed air may cause skin and eyes to be seriously injured.
- As compressed air contains toxic gas etc., compressed air should not be used to be blown or sprayed against food etc.

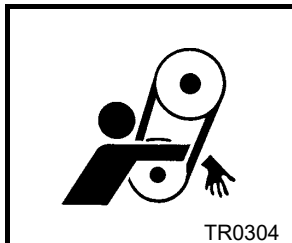

TR0304

- Keep hands away from the rotating machinery or belts during operation.

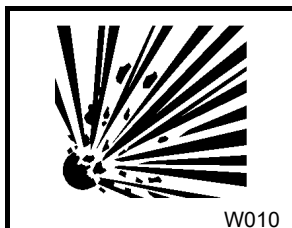

W010

- When you refill the separator receiver tank with compressor oil, stop the engine, and make sure that the pressure gauge indicates 0psi(0bar) and there is no residual pressure in it, and then gradually loosen the oil filler cap for refilling oil.
- Note residual pressure in the separator receiver tank could force both extremely hot compressed air and oil to jet out and you may be scalded or seriously injured.

Safety

WARNING

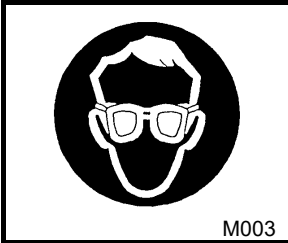

- When cleaning dust accumulated in such devices as the air-filter, by blowing compressed air, wear safety glasses, etc. to protect your eyes.

CAUTION

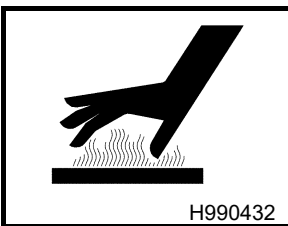

- Be sure to stop the engine, and let the coolant water sufficiently cool down before draining it.
- If the drain valve is opened before the coolant water is cool enough, hot scalding water could jet out, causing burns.

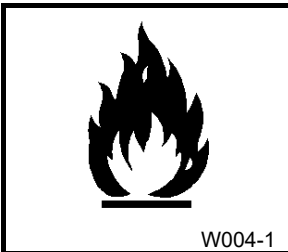

- Be sure to perform the periodic checks of compressor oil and oil separator element.
- Neglecting checks could cause overheat of the oil, resulting in a fire.

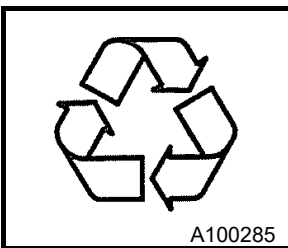

- Waste liquid from the machine contains harmful material. Do not discharge it onto the ground or into the river, lake or sea. Such material will contaminate the environment.
- Be sure to use a container to hold the waste liquid from the machine.
- Be sure to follow the designated regulations when disposing of oil, fuel, coolant (antifreeze), filter, battery or other harmful materials.

- The engine of this machine and electrical parts many electronic devices have been installed. If you perform welding work on this machine, first remove the connector of the electronic control equipment (specifically the ECM). Application of excessive current to electronic controls can cause equipment malfunction.

1. Part Names

1.1 Internal Components and Part Names

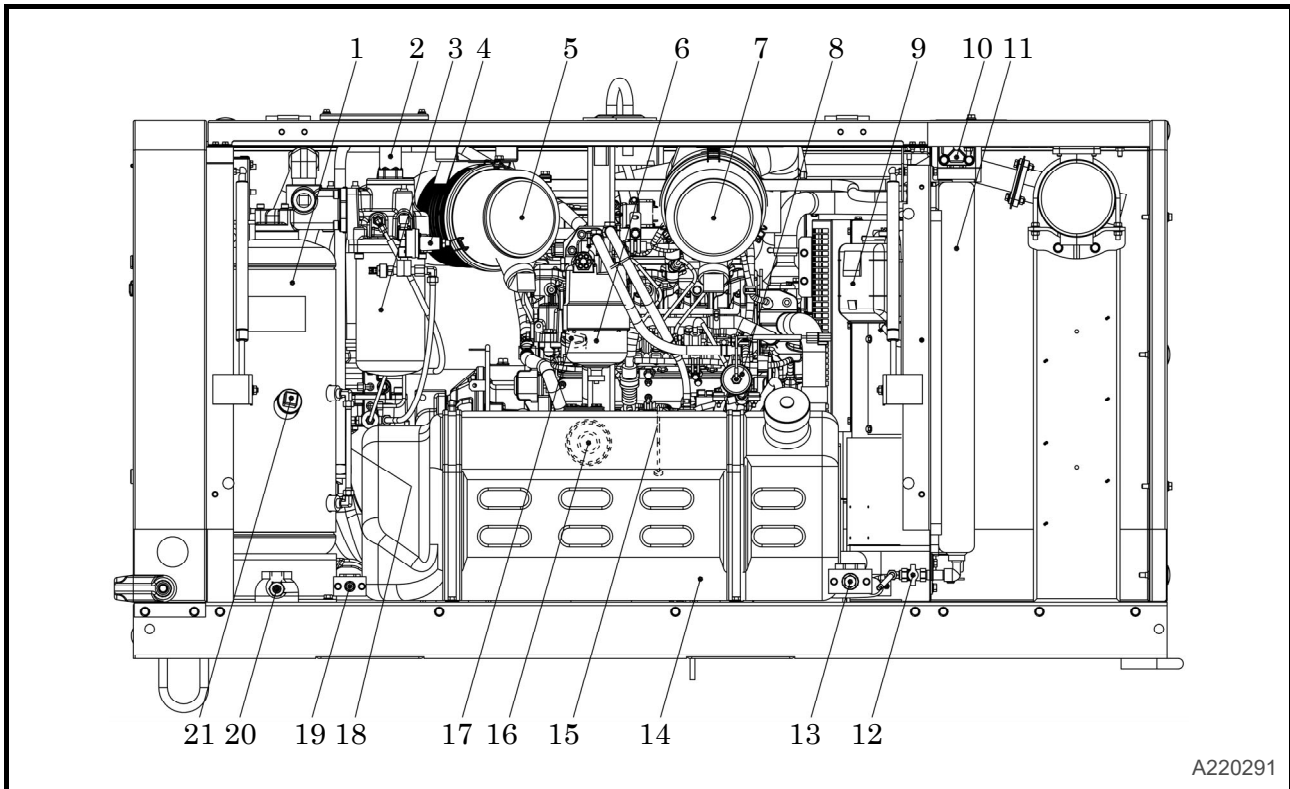

No.	Description	Function
1	Separator receiver tank	For separating air and oil from compressed air in the system.
2	Pressure control valve	For keeping the pressure in separator receiver tank constantly higher than a certain level in the system.
3	Oil separator	For separating oil mist mixed in compressed air.
4	Pressure regulator	For regulating the compressor pressure in the system.
5	Air filter (For compressor air-end)	Filtering device for filtering dust floating in intake air.
6	Fuel filter	Device that filters foreign matter & particulate mixed in fuel.
7	Air filter (For engine)	Filtering device for filtering dust floating in intake air.
8	Air bleeding electromagnetic pump	Device that automatically bleeds air from the fuel lines.
9	Reserve tank	For checking engine cooling water level and for replenishing cooling water.
10	By-pass valve	For keeping compressor oil at proper temperature.
11	Oil cooler	For cooling compressor oil circulating in the system.
12	Oil cooler drain valve	For draining compressor oil out of oil cooler and oil lines.
13	Engine oil drain valve	For draining engine oil for replacement of it and for maintenance.
14	Fuel tank	Vessel for storing fuel.
15	Engine oil level gauge	For checking engine oil level.
16	Engine oil filter	Device that filters engine oil.
17	Engine oil filler port	Port for supplying / replenishing engine oil.
18	Compressor oil level gauge	Scale for measuring compressor oil level.
19	Fuel tank drain valve	For draining condensate accumulated in fuel tank.
20	Separator receiver tank drain valve	From this portion where condensate is drained out of separator-receiver tank.
21	Compressor oil filler port	For supplying and replenishing compressor oil.

1. Part Names

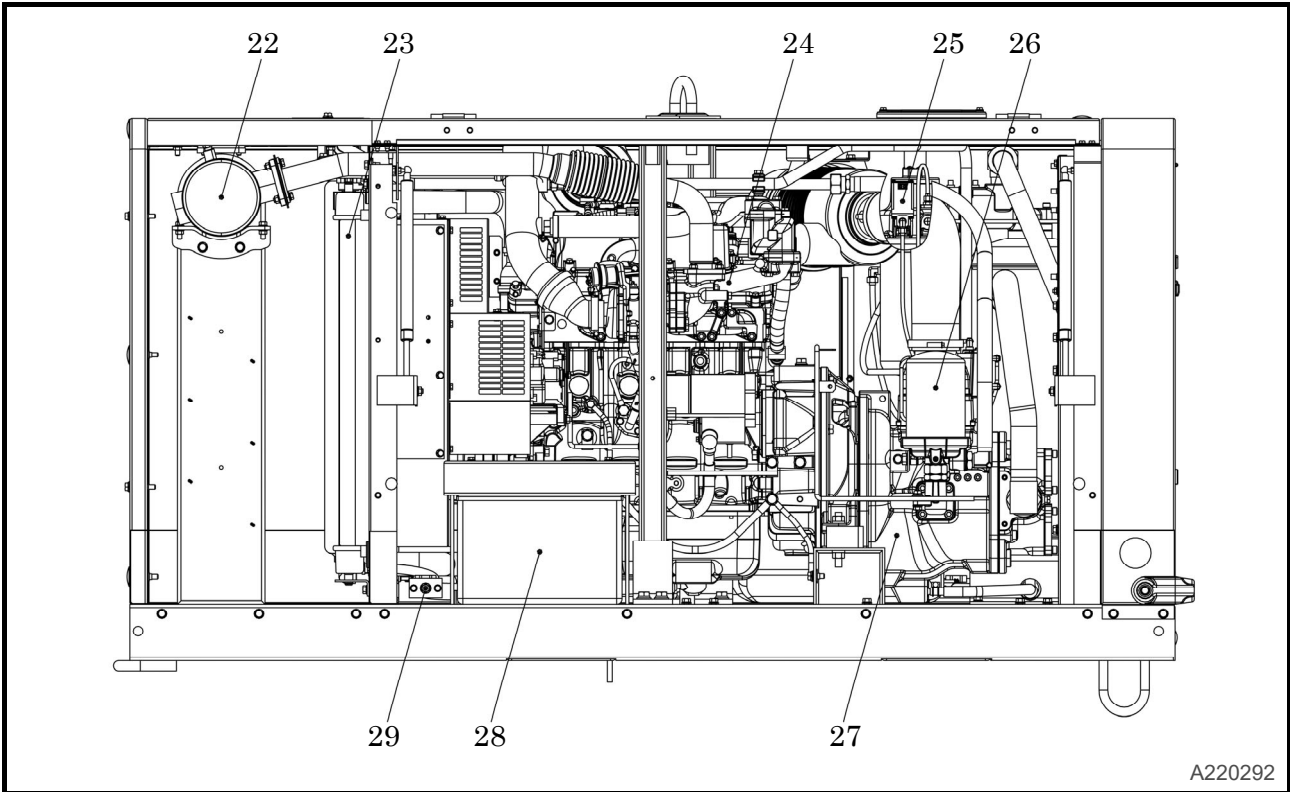

No.	Description	Function
22	DOC (Diesel Oxidation Catalyst)	Catalyst for oxidizing exhaust gas.
23	Radiator	Device that cools the engine coolant.
24	Engine	For driving the compressor.
25	Solenoid valve for starting unload	For reducing load at start-up.
26	Compressor oil filter	For filtering compressor oil circulating in the system.
27	Compressor air-end	For compressing air in the system.
28	Battery	Power source to start the engine.
29	Radiator drain valve	For draining engine coolant.

2. Installation

2.1 Transportation

- When loading and unloading the machine, be sure to use the lifting bail [A] provided on the center of the machine top.

2.1.1 Lifting up

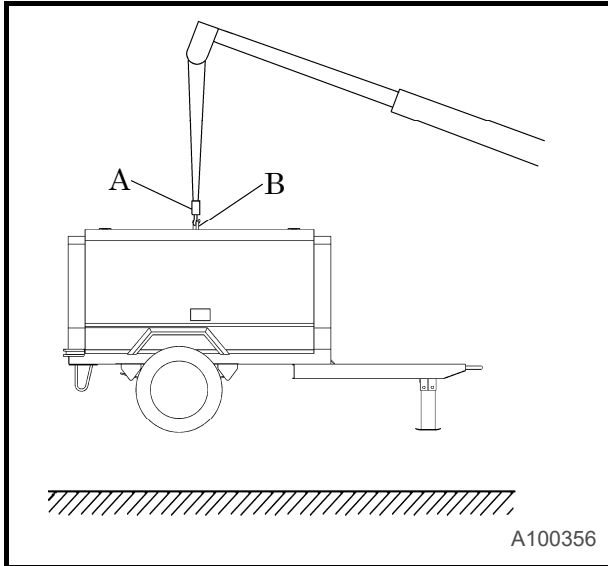

<Procedures>

1. Before lifting the machine up, make sure to check the lifting bail [A] for any crack or loosened bolts.
 2. Connect the hook [B] of the crane or shackle with lifting bail eye fitted at the top center of the machine, and make sure that there is no person standing around the machine. Then perform the hoisting operation.
- Select a truck or a crane with a capacity sufficient for the size and weight of the machine by referring to the values shown in Chapter 7 “Specifications” of the manual.
 - Cranes should only be operated by qualified personnel.

2.1.2 Mounting the machine on the truck bed

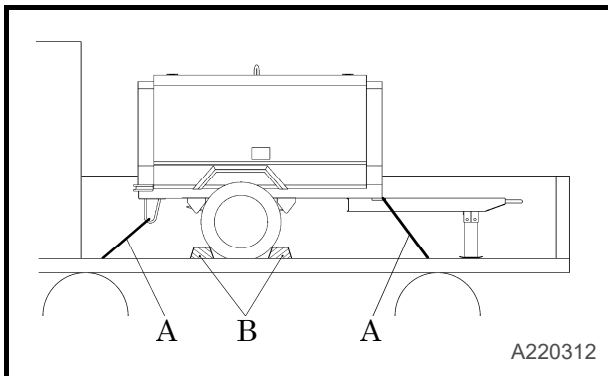

- Be sure to fasten the machine with ropes [A] as shown in the figure right, and securely fix it on the truck bed.
- Be sure to put one set of chocks [B] to the wheels.



WARNING Transportation

- Never get under the machine which is lifted up, because it is very dangerous.
- Never lift the machine which is still in operation, or it could cause critical damage to each component or lead to serious accident.

2. Installation

2.2 Towing the Machine



CAUTION

Caution for towing the machine

- Before towing the machine, make sure to check and confirm that the following points have no problem.
 - Tire air pressure is proper.
 - Tire fixing nuts are not loose.
 - Tires are not worn nor damaged.
- Make sure that the end of the drawbar is so surely and firmly connected to the coupler of the towing vehicle that the disconnection may not occur while the machine is being towed.
- Make sure if there is no deform or damage on the drawing vehicle and the drawbar of the machine.
- Be sure to keep your hand or finger away from any part of the coupling device when coupling or uncoupling a drawing device to a draw bar.
- Be sure to drive the drawing vehicle safely, avoiding dangerous place or ground, if any.
- If you do not follow the above instructions, it could cause serious injury or big damage.

2. Installation

2.3 Installation conditions

- Be sure to use this machine in the following operating environment. If you use the machine not in the conditions stated following, it may causes serious breakdown.
- **Ambient temperature ----- 5°F to 104°F (-15°C to +40°C)**
- **Humidity ----- Less than 80%**
- **Altitude ----- Lower than 4,921ft above sea level**
- **Allowable tilt angle ----- 15° or less**

The machine has to be parked horizontally on a level place. To install this machine on a slope, set it at a right angle to the slope.

- The machine has to be installed in the environment where fresh air is always available, temperature is low and ambient air is dry as much as possible.
- If more than two machines are placed parallel in operation, keep enough distance so that exhaust air from one machine does not affect the other one.
- Also, a machine has to be installed in the environment where fresh air is always available.
- Keep enough space around the machine for inspection and maintenance access.



WARNING

Caution Exhaust gas

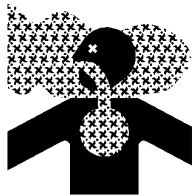

PC002

- Exhaust gas can cause death or serious injury upon inhalation. Avoid using the machine in an insufficiently ventilated building or tunnel.
- Do not position the exhaust gas outlet in direction of a person or a house.

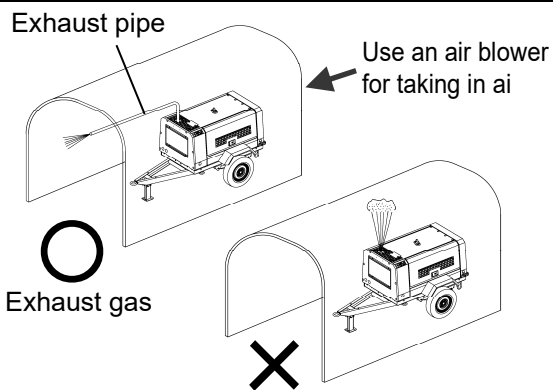

A160725

- When installing the machine in a tunnel or the like, ensure a supply of fresh air and provide adequate ventilation.
- Be sure to place the exhaust pipe in an outdoor location, so that no exhaust gas will be leaked from any pipe seam.

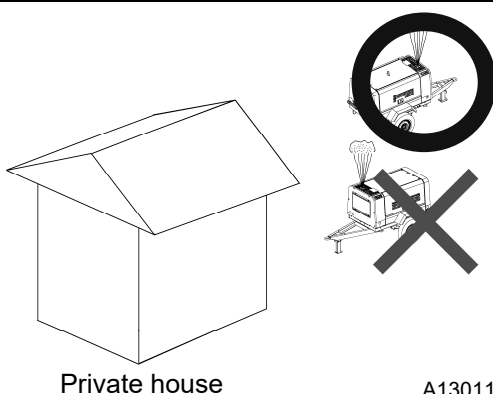

Private house

A130116

- Do not position the exhaust gas outlet in the direction of a house.
- Because the exhaust gas from the engine is poisonous, avoid positioning it in the direction of passers-by.

2. Installation

WARNING Installation notes

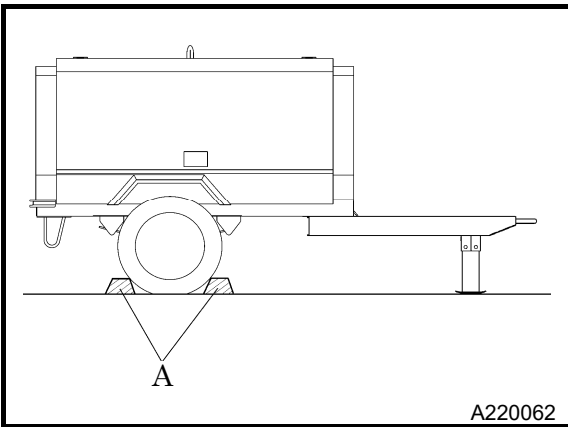

- Be sure to put of chocks [A] to the wheels.

CAUTION Placing safety fence in position

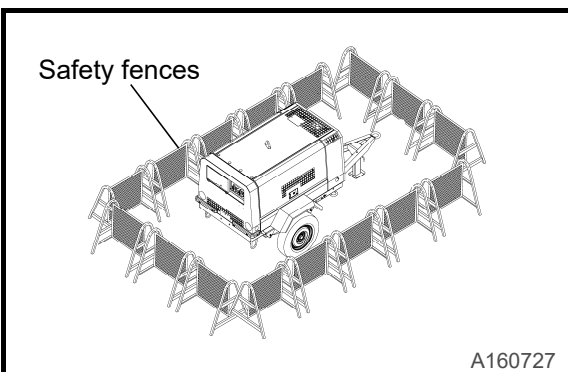

- Be sure to place the safety fence around the machine in order to prevent other people than those involved in construction work from entering the construction site or from accessing the machine

2. Installation

2.3.1 Service valve

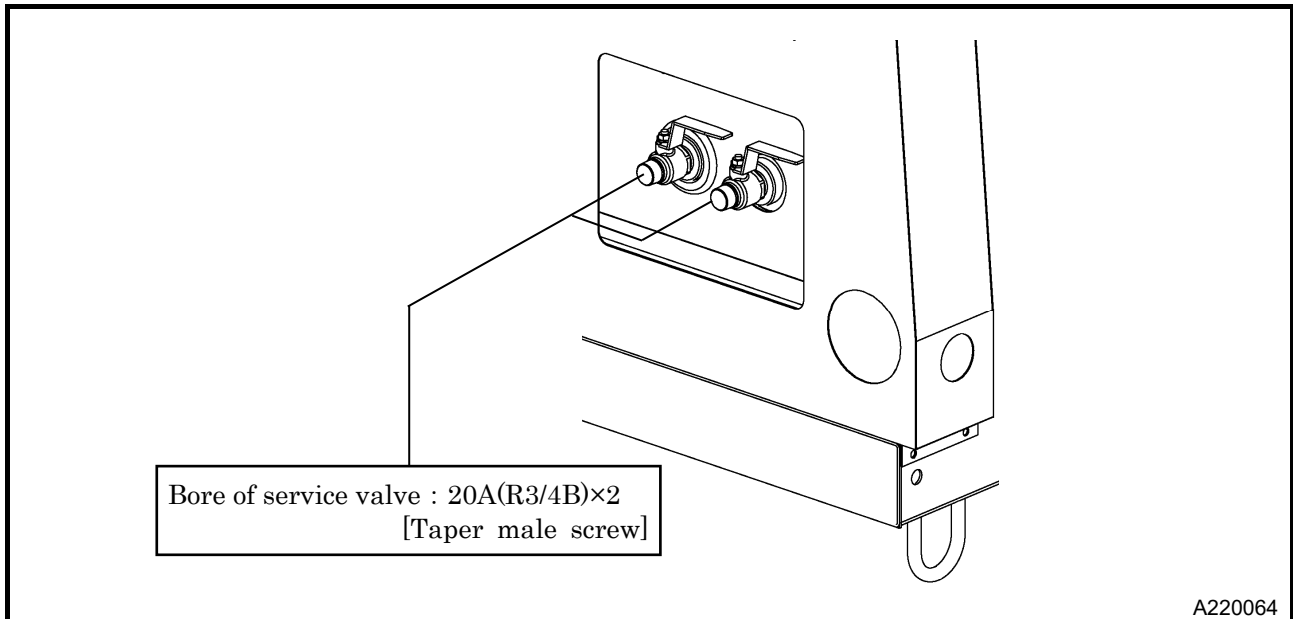

WARNING

Cautions of hose attachment and removal

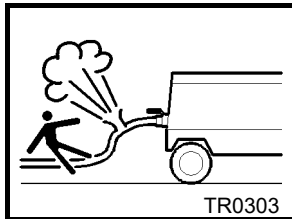
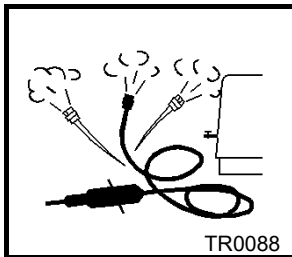

- Piping or the hose from this machine service valve should use what can be borne enough for the safety valve set pressure of this machine.
- Please connect piping or a hose to this machine service valve firmly before operation and during operation.
If the connection is loose, there is a possibility of piping or a hose separating and getting seriously injured.
- Please remove after closing the service valve and relieving remaining pressure. If pressure remains, there is a possibility of the hose whipping, causing damage and possibly injury.
- In order to use it safely, please read the handling of the work tools often used.

CAUTION

Operation with discharge port (compressed air supply port) opened is prohibited

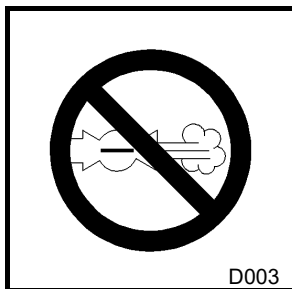

- Do not operate the machine with service valves and relief valve open unless air hoses and/or pipes are connected. High-pressurized air blows out and its air pressure could cause injury to the people nearby.
- When the machine has to be unavoidably temporarily operated with its port open, be sure to mount a silencer to reduce noise and wear protective materials such as earplugs to prevent damage to hearing.

2. Installation



CAUTION

Cautions of service valve

Fully-close

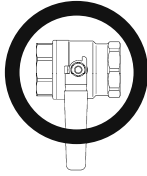

Fully-open

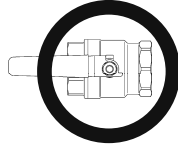

Half-open

A150841

- Half-open of service valve could cause cracks of valve seat and air leaks. Be sure to use as full-close or full-open, not to use as half-open.

3. Operation

3.1 Instrument Panel

Each display of the instrument panel is illustrated as follows.
 Read and fully understand the explanations and be sure to operate safely:

ERROR CODE switch

When this switch is pushed on while lamp is blinking, it shows error code.
 When control power switch to the  position, displayed screen is reset.

※For details of the blinking state (warning) and the illumination state (trouble) of failure codes, refer to 4.1.

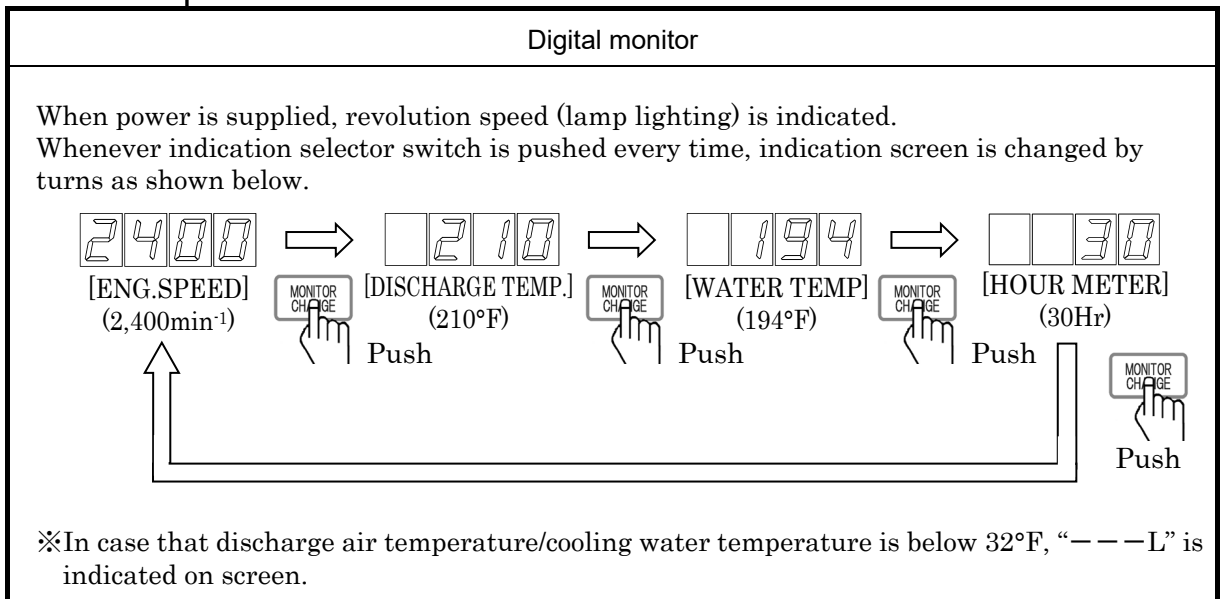
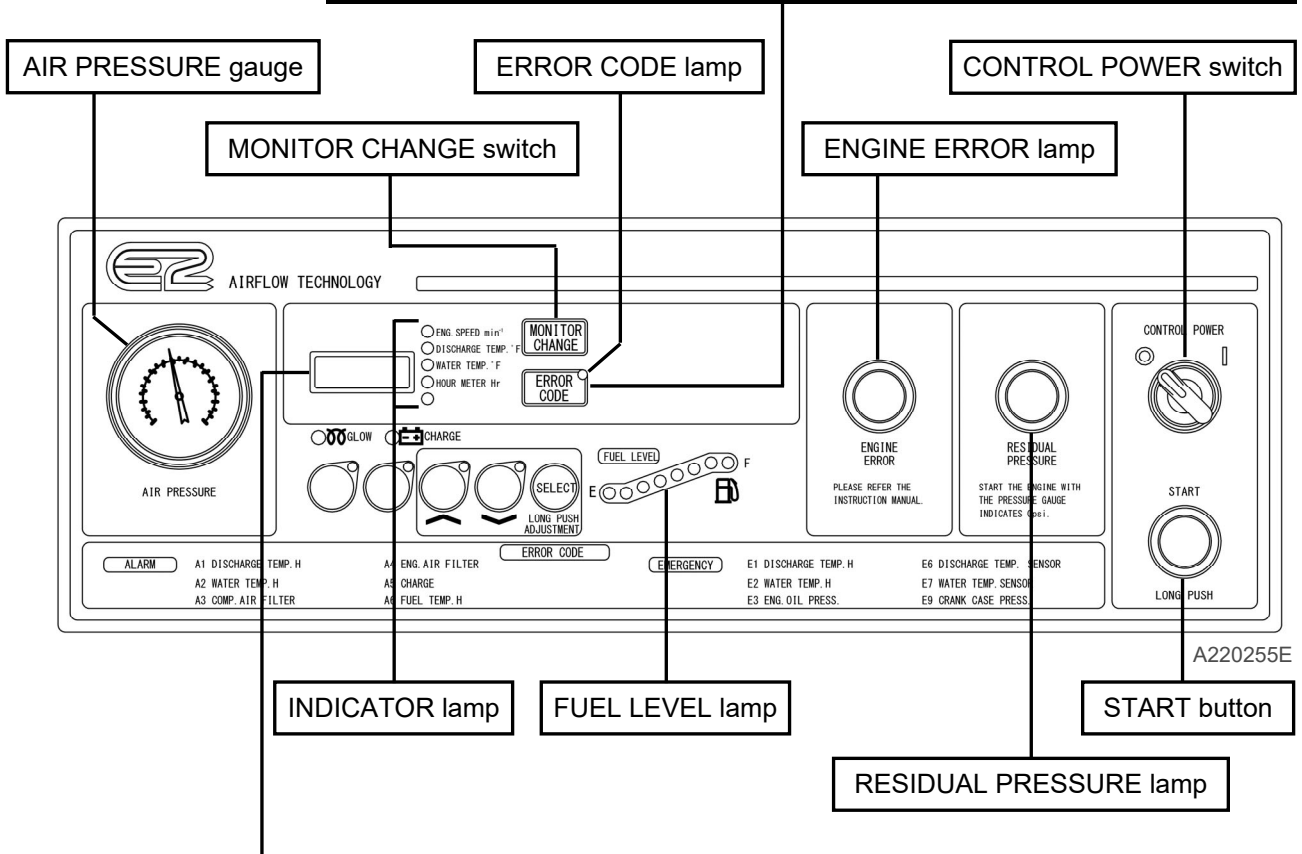

3. Operation

3.2 Lubricating oil • Coolant • Fuel

3.2.1 Engine oil

Use engine oil recommended by us. (Using engine oil with poor quality may shorten the life of the engine)

Classification	API service classification CJ-4 class or higher
Viscosity	SAE10W-40 (delivery condition)

IMPORTANT

- Viscosity of engine oil greatly affects startability, performance, oil consumption of the engine, as well as wear of the moving parts choose appropriate oil based upon the table below according to the outside air temperature.

Ambient temperature range and oil viscosity (SAE)

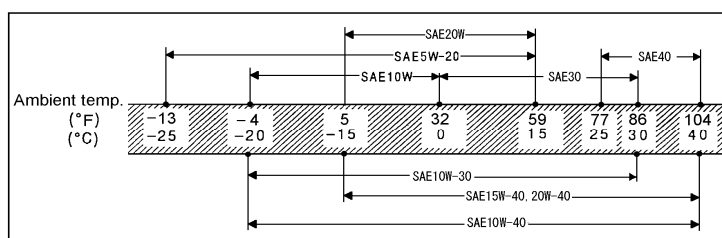

A200331E

- When two or more different brands of oil are mixed, its performance can be deteriorated. Do not mix oils.
- Follow the designated regulations to dispose of engine oil.

3.2.2 Compressor oil

Be sure to use recommended oil listed below. Even continuous oil replenishment cannot improve its deteriorated condition. Be sure to change the oil completely at every scheduled interval.

Maker	Brand
MOBIL	MOBIL RARUS SHC 1024
SHELL	SHELL CORENA S4R (VG32)

IMPORTANT

- Mixture of different brands compressor oil could cause an increase of viscosity and make compressor oil sticky. In the worst case, it could cause sticking trouble of compressor air-end “Compressor air-end will not turn”. Also repairing of such air-end needs expensive cost. Therefore, be sure to avoid mixing different brands oil. In case compressor oil brand in use has to be unavoidably changed, it is absolutely necessary to completely clean up the interior of compressor air-end. In such a case, contact your nearest dealer.
- Follow the designated regulations to dispose of compressor oil.

3. Operation

3.2.3 Coolant

Use coolant that is a mixture of LLC (antifreeze) and soft water of good quality such as tap water.

IMPORTANT

- If you use water mixed with soil, sand, or dust, or soft water such as well water (ground water), water will easily accumulate in the coolant channels of the engine and radiator, leading to an increase in the coolant temperature.
- Freezing the coolant can damage the engine and radiator. Adjust the LLC (antifreeze) mixing ratio within the range of 30-60% depending on the outside temperature. If the mixing ratio exceeds 60%, the antifreeze effect will decrease. At the time of factory shipment, coolant with a mixing ratio of 55% is filled.

Mixing ratio of LLC (antifreeze) (reference)

Outside temperature (°F)	5	-4	-13	-22	-31	-40	-49
Outside temperature (°C)	-15	-20	-25	-30	-35	-40	-45
Mixing ratio (%)	30	35	40	45	50	55	60

- Use LLC (antifreeze) which conforms to one of such standards : SAE J814, SAE J1034 and ASTM D3306.
- **Follow the designated regulations to dispose of LLC (antifreeze).**

3.2.4 Fuel

CAUTION

- Diesel fuel is required to meet the following characteristics:
 - Free from even fine dust particulate
 - Appropriate viscosity grade
 - It must have high cetane number. (greater than 45)
 - It must have high fluidity even at low temperature.
 - Carbon residue content in fuel must be a little.

IMPORTANT

- Do not use such diesel fuel having higher sulfur content above 0.0015%(15 ppm)
- Use ultra-low sulfur diesel fuel only for diesel engine.
- Use such diesel fuel which conforms to either EN590 or ASTM D975 standard.
- Do not use kerosene. And never use fuel mixed with kerosene.
- **Follow the designated regulations to dispose of fuel.**

3. Operation

3.3 Check before starting unit

Be sure to check the unit before operation. When any abnormality is found, be sure to repair it before restarting the unit. Be sure to make daily checks before operation. If the unit is operated without prior check and without noticing its abnormality, such operation could cause seizure of components or may even cause fire.

3.3.1 Check engine oil level

Place the machine on level ground when checking the oil level. If you check engine oil level after starting operation, be sure to check it after 10 minutes or more have elapsed since stopping the engine.

<Procedures>

1. Pull out the oil level gauge [A], and wipe it with a clean cloth.
 2. Then, re-insert the oil level gauge fully and pull it out again. If the oil level gauge shows the oil level between upper limit and lower limit, it is normal.
 3. When the oil level is below its lower limit, add engine oil from oil filler port [B].
- While checking oil level, check also for contamination. If the oil is found dirty, contaminated or should it be changed according to the periodic inspection list, change the oil. (See 5.5.1)
 - Excessive engine oil supply could cause engine output degradation. Therefore, never fill more than the upper limit.

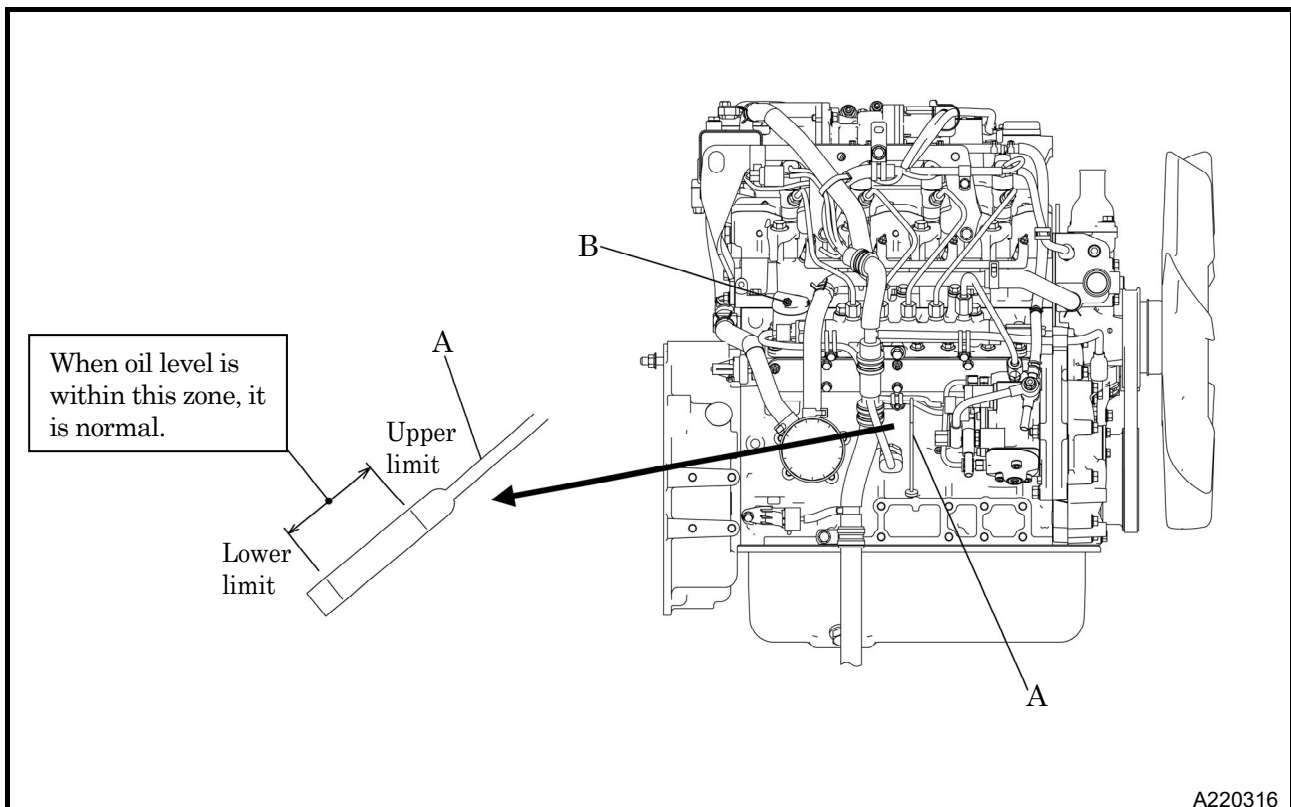

3. Operation

3.3.2 Check coolant level

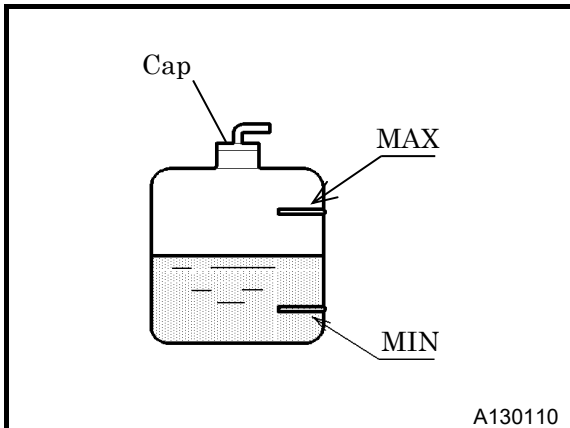

- Verify the coolant level in the reserve tank is above [MIN].
- If the coolant level is lower than [MIN], remove the cap and supply coolant up to the center between [MIN] and [MAX]. If too much coolant is poured into the reserve tank, it may overflow during operation.
- If there is no coolant in the reserve tank, remove the radiator cap and add coolant directly through the radiator fill port. (See 5.5.17)

CAUTION

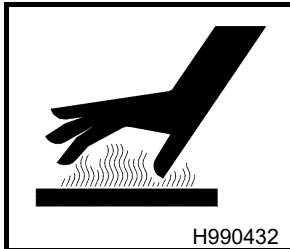

- When removing the radiator cap, lightly turn it and release the internal pressure without completely opening it once the first stage lock is released. After confirming that the internal pressure has been released, turn it while pushing in until the second stage lock is released. If this procedure is neglected, its inner pressure can blow off the radiator cap, and steam jetting out of the radiator may cause scalding burns.

IMPORTANT

- If the engine is operated with insufficient cooling water, the engine may be damaged.

3. Operation

3.3.3 Check compressor oil level

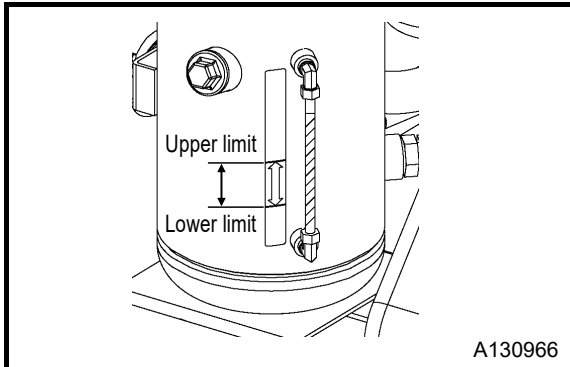

- The machine should be on level before checking compressor oil level.
- The oil level of this machine will vary depending on whether it is in operation or not. When it is not in operation, make sure that the compressor oil level is above the upper limit line as shown in red on the level gauge plate. Replenish the oil if short.
(See 5.5.6)
- ※ Supply of excessive oil can cause deterioration of oil separation performance and the like.

WARNING

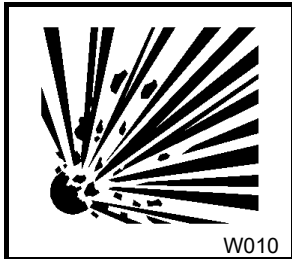

- When you refill the separator receiver tank with compressor oil, stop the engine, and make sure that the pressure gauge indicates 0psi (0bar) and there is no residual pressure in it, and then gradually loosen the oil filler cap for refilling oil.
- Note residual pressure in the receiver tank could force both extremely hot compressed air and oil to jet out and you may be scalded or seriously injured.

3.3.4 Drain separator receiver tank

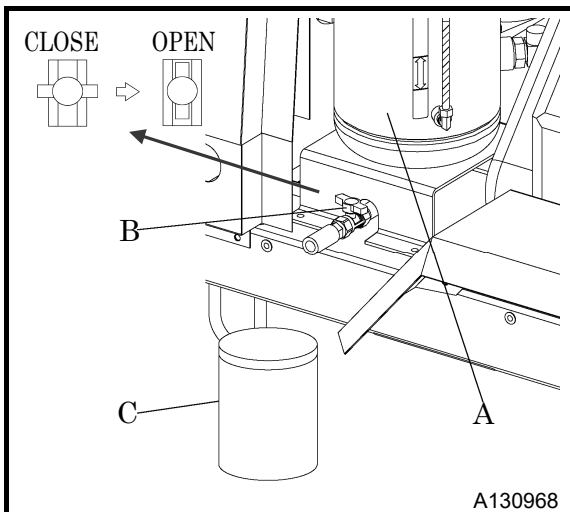

- Gradually opening the drain valve [B] fitted under the separator receiver tank [A] as shown in the fig, drain the condensate.
- When all the condensate is drained away and the compressor oil starts to come out, close the drain valve.
- Drain the condensate in container [C], and then dispose of condensate according to the designated regulations.
- When the fluid is difficult to distinguish by appearance, use a gloved hand and check its viscosity via touch to determine whether it is condensate or compressor oil.

WARNING

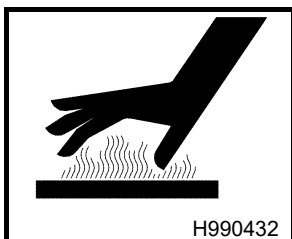

- After stopping the engine, confirm that the pressure gauge indicates 0psi (0bar) and there is no residual pressure in it, then open the drain valve gradually to drain the compressor oil.
- Should any residual pressure be left in the separator receiver tank, hot compressed air and hot compressor oil jetting out could cause burning or serious injury to persons nearby.
- A long-time operation with condensate accumulated could cause rust in the interior of compressor air-end, resulting in serious trouble.

3. Operation

3.3.5 Check fuel

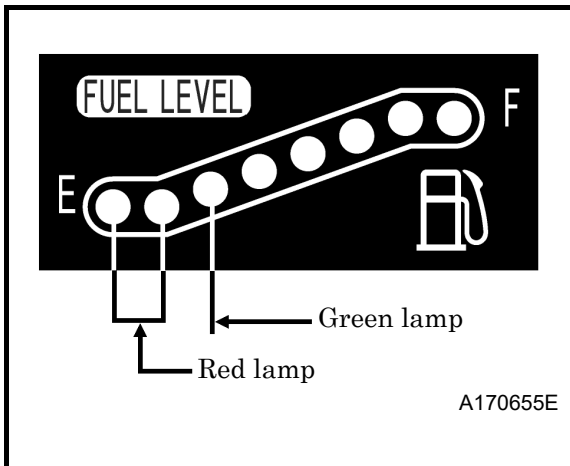

Before starting operation, make sure to check the level of residual fuel so that fuel shortage during operation can be avoided. Drain condensate accumulated at the bottom of fuel tank whenever necessary.

- Refueling should be done outdoors or in a well-ventilated place. Lamp is ON according to fuel level when CONTROL POWER switch of instrument panel is set to  position. Two red lamps are ON when fuel level is about 1/3 or less of maximum level. Only one red lamp blinks when fuel level becomes more less. Replenish fuel quickly when lamp is ON as red.

- **Do not fill fuel up to the filler level.**

When the fuel tank is filled up to the filler level, the expansion volume of the tank is too small and may lead to problems with fuel flow and containment. Furthermore, fuel may spill from the fuel tank due to vibration caused during movement or transportation of the unit.

CAUTION



- Do not, under any circumstance, bring lit cigarettes and/or matches near fuel.
- The fuel is extremely flammable and dangerous. Be aware of fire sources that can easily ignite the fuel.
- Refuel only after stopping the engine, and never leave open fuel cans near the machine. Do not spill. It is a fire hazard. When spills occur, wipe up thoroughly.
- Never use alcohol-base cleaning fluid. If it sticks to such parts made of plastic, it causes degradation of liquid surface visibility, and in worst case, it leads to crack and fuel leak due to crack caused.

3.3.6 Drain fuel tank condensate

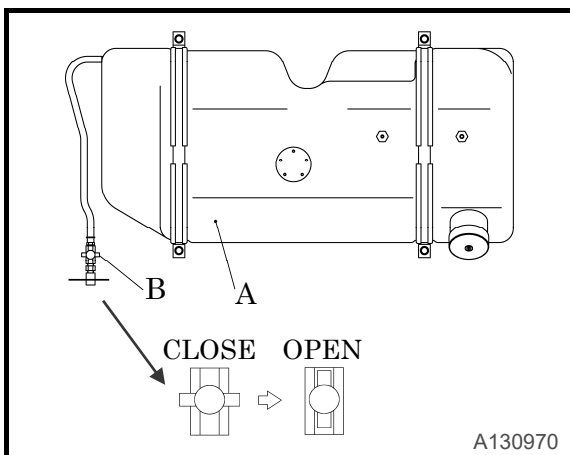

- Gradually open the drain valve [B] on the left side the fuel tank [A], drain the condensate from the tank.
- When all the condensate is drained away and the fuel starts to come out, firmly shut the drain valve [B].
- Drain the condensate in container, and then dispose of condensate according to the designated regulations.

3. Operation

3.3.7 Check fuel filter for condensate

If the red float [A] inside the fuel filter is above line, drain water from the fuel filter.

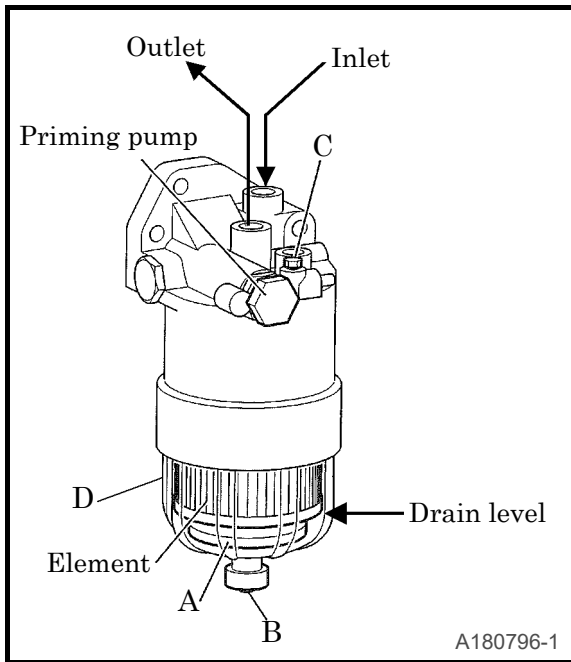

<Procedures>

1. Before draining water, attach a drain hose to the drain plug [B].
 2. Prepare a container. Loosen drain plug [B] and air bleeding plug [C] to drain.
 3. After draining finished, be sure to tighten [B] and [C].
- Do not remove fuel filter case as fuel is overflow if it is removed. If it is necessary to remove it, plug inlet hose with a clip etc.
 - Drain the condensate in container, and then dispose of condensate according to the designated regulations.

CAUTION

- When checking, do not use alcoholic parts cleaner for cleaning. If it sticks to plastic parts, which might causes cracks and less visual recognition for fuel level. In worst case, which might causes cracks and fuel leaks.

3.3.8 Check wiring of each part

Check each wiring for any loose connection, damage to insulating sheathed portion, disconnection, and short-circuit.

3.3.9 Check piping of each part

Check each piping for any loose connection and also check each hose and pipe for any tear and leaks.

3. Operation

3.3.10 Check belt tension

Follow the procedure below to adjust tension of belt for alternator.

Adjust the tension by gradually loosening the fastening bolt and nut of the alternator.

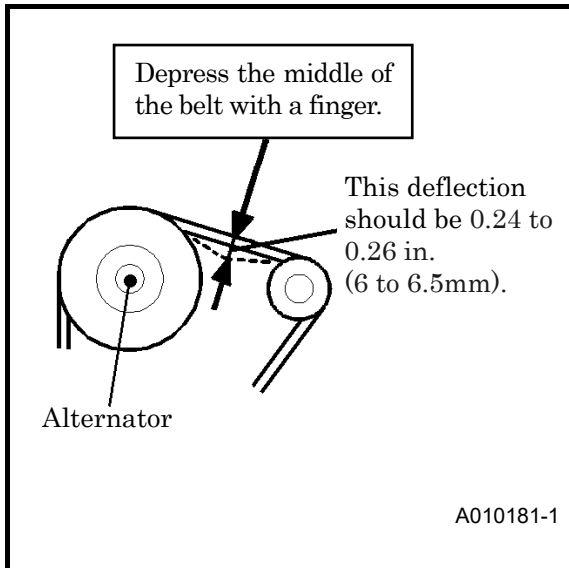

<Procedures>

1. Visually check if there are any cracks or tears in the belt.
 2. Check if the deflection is between 0.24 to 0.26 in. (6 to 6.5mm) when the belt is pushed at the center with a force of about 22 lbf (98N). If not, loosen the adjustment bolt of the alternator once and adjust again.
 3. Tighten the alternator mounting bolt when the adjustment is completed.
- Be careful not to leave any grease or LLC on a belt while changing it. If any such material is left, wipe it off completely.
 - For details of adjustment, refer to the engine operation manual.

WARNING

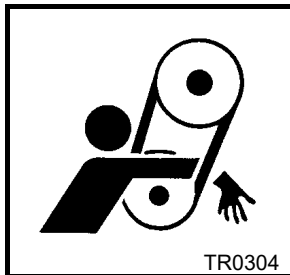

- Be sure to stop the engine whenever the tension of the belt is to be adjusted.
- Remove the negative (-) side cable from the battery.
- If the unit is not stopped, the operator's hand may be caught in the belt and cause serious injury.
- If inspecting or maintaining the area near the cooling fan, always stop the machine before going forward.
- Otherwise, personnel could become caught by the fan and thus could be seriously injured.

IMPORTANT

- Too tight belt tension could damage shaft and shorten bearing life. Too loose belt tension may result in damaging belt earlier and machine components due to overheat.

3. Operation

3.3.11 Periodical Inspection of Machine Insides

Periodically check the inside of the machine for dusts (rubbishes) and flammables.

CAUTION

- Be sure to wear protector such as helmet, protective glasses, earplug, safety shoes, gloves and dust protective mask for safety operation conforming with details of work.
- When any flammables such as chips of wood, dead leaves (dry leaves) and waste paper are left near heated exhaust muffler and heated exhaust pipe, all of them should be eliminated.
- Keep a fire extinguisher on hand near the machine in case of fire hazards.
- It is helpful to keep emergency contact numbers for urgent visit clinic, ambulance and firehouse.

3.3.12 Opening and closing doors

To open the door, pull the handle toward you to release the latch. Be sure to close the door tightly so that its latch is firmly caught.

WARNING



- Keep the door closed and locked while running the unit.
- When the door has to be opened, be careful not to touch portions that are rotating or very hot. Scalding burns or serious injury may result.

3. Operation

3.4 Operating Procedure



Make sure the door is closed securely.

3.4.1 Procedure to start the unit

Follow the steps below to start up.

During the warm-up operation, examine the different parts of the equipment for any looseness, leakage of water, oil, fuel, and other irregularities. Also, make sure that the error code lamp on the instrument panel is off.

<Procedures>

1. Ascertain that the discharge air pressure gauge [A] indicates 0 psi (0 bar).
2. Fully close the service valves
3. Turn the CONTROL POWER switch [B] from  to . GLOW lamp [C] goes on.
4. Immediately after the GLOW lamp goes off, press and hold down the START button [D] for one second or more to start the engine.

The startup operation will stop automatically if it takes more than 30 seconds. If the machine fails to start after one attempt, wait for at least one minute before attempting to start it again. It could cause overheating to the starter motor and it could damage it. (See 3.4.2)

- If the START button is pressed while a certain residual pressure is left in the separator receiver tank, the residual pressure start lamp [E] will turn on but the starter will not rotate. Please make sure that it is the 0 psi(0 bar) residual pressure remains always.
5. Once the engine has started up, leave it running to warm-up for 5 minutes.
 - After the engine starts up, the startup unload operation will automatically be performed. According to engine cooling water temperature, the times in the following table are required.

Engine coolant temperature	Required time for starting unloader operation
Higher than 50°F(10°C)	30 sec
Lower than 50°F(10°C)	Shorter time either 120 seconds or the time when engine coolant temperature becomes higher than 50°F (10°C).

During the startup unload operation, compressed air will not be discharged.

6. After finishing warming up operation, open the service valve provided at the outlet of compressed air and start service job.

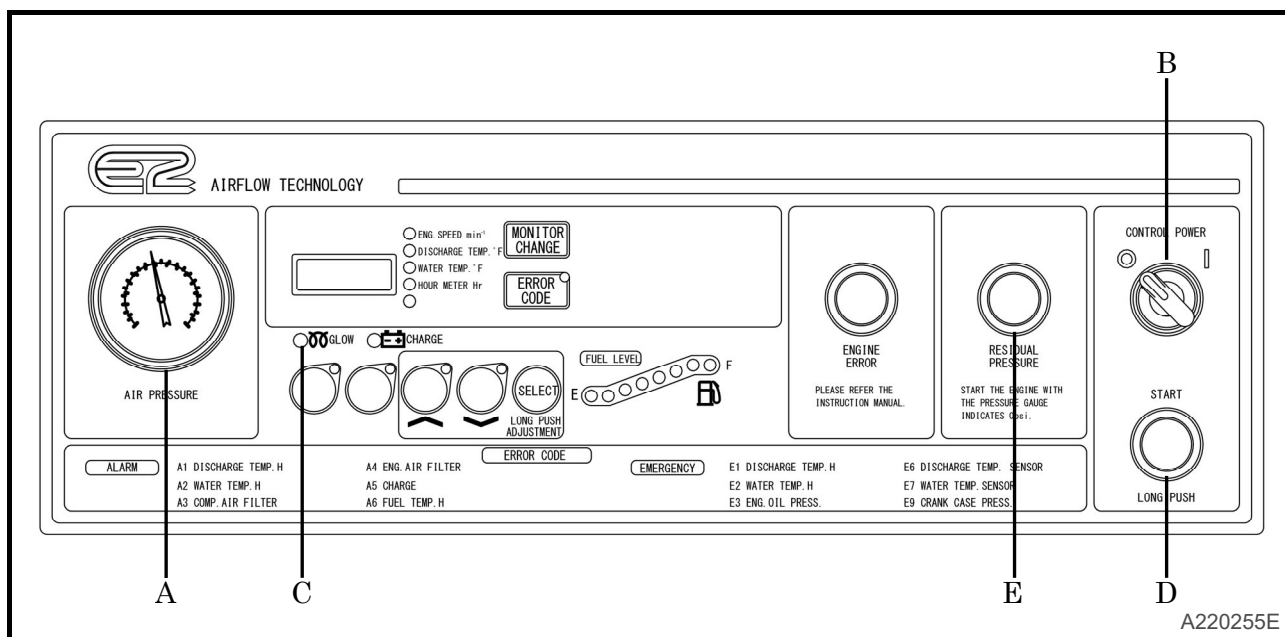

A220255E

3. Operation

CAUTION

- Do not operate the machine with service valves and relief valve open unless air hoses and/or pipes are connected. High-pressurized air blows out and its air pressure could cause injury to the people nearby.
- When the machine has to be unavoidably temporarily operated with its port open, be sure to mount a silencer to reduce noise and wear protective materials such as earplugs to prevent damage to hearing.

IMPORTANT

- Be sure to let unit warm-up after starting for smooth operation of the engine and the compressor.
- Do not carry out on-load operations immediately after turning the machine on, as this could result in a shorter machine life.

3.4.2 Operating procedures when engine fails to start up on first attempt

If the engine did not start even when you performed Steps 1 through 4 of Section 3.4.1, return the CONTROL POWER switch [B] to the  position and wait 1 minutes or more. Then, perform the engine-starting operation again. If the repeated procedure does not allow the engine to run, the following causes are suspected. Therefore, check the following:

- No fuel
- Lack of air bleeding in fuel line. (See 3.4.6)
- Fuel filter clogging.
- Battery discharge (Low cranking speed)

3.4.3 Operation in cold weather

- Use engine oil of a viscosity that meets the ambient temperature according to 3.2.1.
- Use LLC (antifreeze). Use correct amount to provide freeze protection, according to the ambient temperature according to 3.2.3.
- Battery should always be kept fully charged.

CAUTION

- When operating the unit in a low temperature, change engine oil, compressor oil, LLC (antifreeze) and diesel fuel according to the ambient temperature.

3. Operation



3.4.4 Display of each panel device in operation

Be sure to check at times to see if gauges or each component of the unit are properly working, or if there is any air-leak, oil-leak, water-leak or fuel-leak etc. During normal operation, each indication of instruments is shown in the table below.

Refer to the table for daily checks.

- The above table gives standard values. They may vary slightly depending on the operating conditions and other factors.

Operating condition		Air pressure gauge	※1 Digital monitor (For engine speed)
Before startup (CONTROL POWER switch set to  position)		—	0
Starting unloaded operation		About 44psi (3bar)	Approx. 1,250min ⁻¹
In operation	Unload	116 to 131psi (8 to 9bar)	Approx. 1,250min ⁻¹
	Full load	58 to 100psi (4 to 6.9bar)	Approx. 2,400min ⁻¹

Operating condition		Indicator lamp					
		GLOW	CHARGE	FUEL	ENGINE ERROR	RESIDUAL PRESSURE	ERROR CODE
Before startup (CONTROL POWER switch set to  position)		● OFF ※2	 ON	 ON Changes depending on the remaining quantity	● OFF ※3	● OFF	● OFF ※3
Starting unloaded operation		● OFF	● OFF		● OFF	● OFF	● OFF
In operation	Unload	● OFF	● OFF		● OFF	● OFF	● OFF
	Full load	● OFF	● OFF		● OFF	● OFF	● OFF

※1: The display will switch. For details, see 3-1.

※2: This lamp will be OFF in 0 to 10 seconds, (varying upon ambient temperature.)

※3: This lamp will be OFF in about 2 seconds.

3. Operation

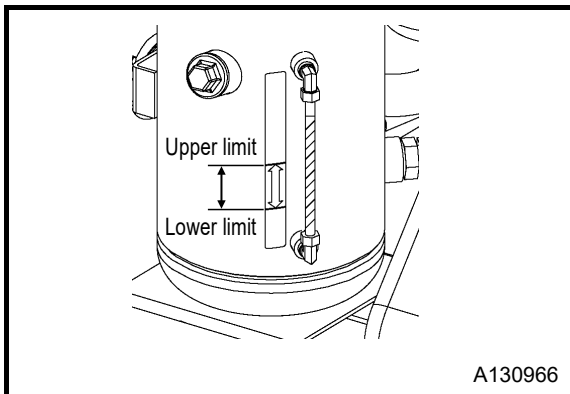

- When the machine is in operation under load, check to see that the compressor's oil level falls within the range between the lower limit and upper limit of the level gauge if the level is found to be insufficient, replenish the oil.
- ※ Keep the operation log to record constant inspection of each component, so that trouble of the machine can be easily discovered and preventive measures can be taken.

CAUTION



- Do not open the valves below listed when operating.
- Separator receiver tank condensate drain valve
- Radiator drain valve
- Engine oil condensate drain valve
- Oil cooler condensate drain valve
- Fuel tank condensate drain valve

IMPORTANT

- Minimum discharge air pressure is 58psi (4bar) during operation.
- Continuing equipment operation at a lower pressure than the above pressure may cause overheating, since it affects the separation of compressor oil inside the oil separator and reduces the compressor oil flow to the compressor air-end, resulting in temperature rise. (See 5.5.28)

3.4.5 Procedure to stop the machine

<Procedures>

1. Close the service valve completely and operate the machine about 5 minutes, until it cools down.
2. Turn the CONTROL POWER switch to the position .
3. After the engine stops, close the door located on the front of the instrument panel and then lock the door with the key. Remove the key and keep it in a safe place.

3. Operation

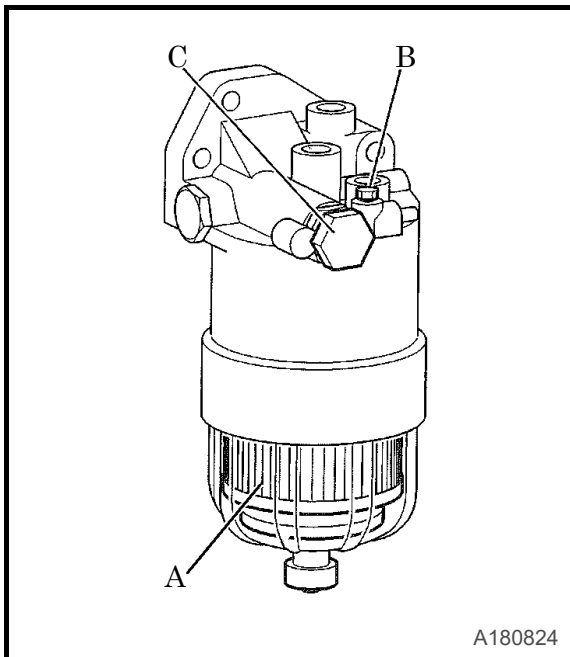

3.4.6 Air bleeding in fuel line

Should the machine stop due to fuel shortage, perform air bleeding according to the following steps.



A180824

<Procedures>

1. Refuel.
2. Turn the CONTROL POWER switch to the  position, and then activate the electromagnet pump.
3. Loosen the air bleeding plug [B] of the fuel filter element [A] and loosen the priming pump [C], push the priming pump back and forth until fuel comes out (more than 20 times).
4. After air bleeding is completed, tighten the air bleeding plug [B] and push the priming pump [C] back and forth until the fuel filter element [A] is filled with fuel (more than 10 times).
5. After waiting about 1 minute, loosen air bleeding plug [B] to bleed air from fuel filter element [A].
6. Repeat the above procedures 3. to 5. till air does not come out from air bleeding plug [B].
7. Finally, tighten both the air bleeding plug [B] and the priming pump [C], turn the CONTROL POWER switch to the  position, and then wipe off the surrounding fuel.

Air bleeding plug tightening torque: 88.5lb · in.

- For details, refer to the engine operation manual.



CAUTION

- Tighten the air bleeding plug firmly to the specified torque. Loosening of the air bleeding plug may cause fuel leakage.

4. Failure cause and measures

4.1 Indicator lamp and Warning / Emergency display

[Indicator lamp]

Item	Contents	Measures	Monitor
GLOW	CONTROL POWER switch  and the lamp goes on and after preheating is finished, the lamp will be off.	—	
CHARGE	Lamp goes on when alternator is not charging.	Check wiring. Check alternator.	

4.1.1 Warning Display

This displays such trouble of less importance when it occurs during operation, but the unit continues operating. When any abnormality happens, a trouble code lamp flickers. In this time when trouble code switch is pressed, a failure code will be digital monitor.

Item	Failure code	Contents	Measures
DISCHARGE TEMP. H	A-1	Lamp displays when the discharge air temperature at the outlet of the compressor air-end reaches 239°F (115°C).	See 4.2 “Troubleshooting”
WATER TEMP.H	A-2	Lamp displays when engine coolant temperature reaches 201°F (94°C).	
COMP.AIR FILTER	A-3	When the air filter gets clogged and suction resistance increases, lamp comes on. [Actuating resistance is more than 0.9psi (0.062bar).]	Clean or replace
ENG. AIR FILTER	A-4		
CHARGE	A-5	Belt loosened and/or cut Faulty generation of alternator	See 4.2
FUEL TEMP.H	A-6	Lamp displays when fuel temperature reaches 167°F (75°C).	“Troubleshooting”

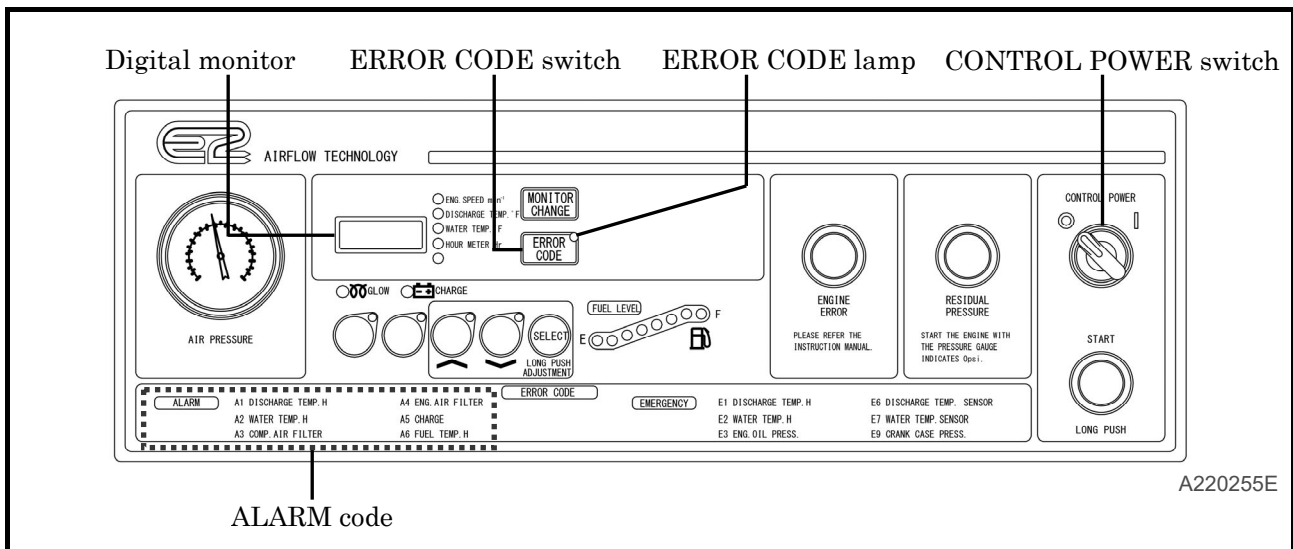

4. Failure cause and measures

4.1.2 Emergency Display

When any trouble takes place during operation, this displays and it stops as an emergency stop. When any abnormality happens, a trouble code lamp flickers. In this time when trouble code switch is pressed, a failure code will be digital monitor.

Item	Failure code	Contents	Measures
DISCHARGE TEMP. H	E-1	Lamp displays when the discharge air temperature at the outlet of the compressor air-end reaches 248°F (120°C).	See 4.2 “Troubleshooting”
WATER TEMP.H	E-2	Lamp displays when engine coolant temperature reaches 210°F(99°C).	
ENG. OIL PRESS.	E-3	Lamp goes on when engine oil pressure drops. [The function pressure : 14psi(0.98bar)]	
DISCHARGE TEMP. SENSOR	E-6	Discharge air temperature sensor of the discharge air outlet disconnected.	
WATER TEMP. SENSOR	E-7	It is displayed when engine coolant temperature sensor is disconnected.	
CRARK CASE PRESS.	E-9	It is displayed when the internal pressure of the crank case rises. [The function pressure: 1.0±0.3psi(0.069±0.02bar)]	

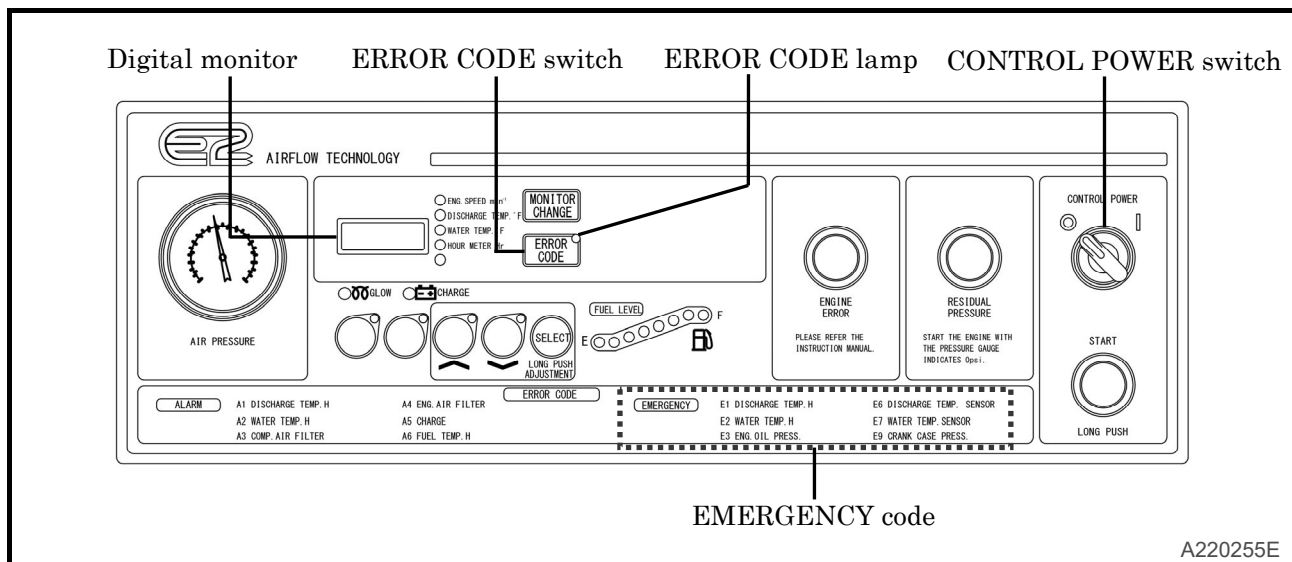

4. Failure cause and measures

4.2 Troubleshooting

Should any trouble occur during operation, do not leave it. Investigate the cause and take appropriate measures. Read the manual carefully and fully understand what to do in case of trouble.

- The better you understand the construction and function of the unit, the faster you can find the problem and solution.
- This chapter describes the symptom, cause and countermeasures of important troubles in detail.

Symptom	Cause	Countermeasures
Low starter revolution speed.	(1) Faulty battery (2) Failure of battery charging (3) Faulty alternator (4) Faulty starter	Check battery→Charge Change Change
The starter rotates normally but the engine does not start.	(1) Fuel filter clogging. (2) No fuel (3) Air entry into fuel line system (4) Nozzle clogging	Disassemble, clean, and change Fuel replenishment Bleed air Disassemble/Clean
The discharge air pressure will not rise.	(1) Pressure regulator insufficient adjustment. (2) Trouble of solenoid valve for starting unloader.	Re-adjust (fasten) Change
The engine does not reach the rated revolution speed.	(1) Faulty engine controller (2) Failure of the emergency controller. (3) Unloader orifice clogging. (4) Engine trouble. (5) Fuel filter clogging. (6) Water is accumulated in fuel filter. (7) Air filter element clogging. (8) The engine-protecting function being in use. (coolant rising /fuel temperature rising) (9) Disconnection of the solenoid valve for starting unloader.	Call your nearest dealer Call your nearest dealer Disassemble/Clean Call your nearest dealer Disassemble/Change Drain water Clean or change of element Unload operation or stop the engine Change solenoid valve for starting unloader
If the discharge pressure will not increase to the specified one, RPM will drop.	(1) Pressure regulator insufficient adjustment. (2) Trouble of pressure regulator. (3) Unloader orifice clogging.	Re-adjust (fasten) Change Disassemble/Check
Engine does not reach minimum revolution at unload.	(1) Failure of the engine controller (2) Failure of the emergency controller.	Call your nearest dealer Call your nearest dealer
Safety valve relieves at unload.	(1) Pressure regulator insufficient adjustment. (2) Unloader valve damaged· Faulty seat (3) Faulty safety valve.	Re-adjust (loosen) Change Change
Oil mixes in air. (poor oil separation)	(1) Scavenging orifice strainer clogging. (2) Excessive oil in separator receiver tank. (3) Low discharge pressure. (4) Oil separator element deteriorated.	Disassemble/Clean Drain to its proper level Disassemble and check of pressure control valve Check /Change

4. Failure cause and measures

Symptom	Cause	Countermeasures
Insufficient free air delivery.	(1) Air filter element clogging. (2) Unloader valve cannot fully open. (3) Engine does not reach rated speed.	Clean or change of element Call your nearest dealer (See 4-3)
Discharge temperature alarm (A-1). Discharge temperature error (E-1) and engine stoppage.	(1) Oil cooler clogging. (2) Oil filter clogging. (3) Faulty discharged air temp. switch. (4) Loosened or disconnected wiring or connectors (5) Belt slippage. (6) Shortage of compressor oil. (7) Malfunction of the by-pass valve	Clean Change Change Check/Fasten Re-adjust tension Replenish compressor oil Check /Change
Water temperature alarm (A-2). Water temperature error (E-2) and engine stoppage.	(1) Clogged radiator. (2) Faulty thermostat. (3) Faulty coolant temp. switch. (4) Coolant shortage. (5) Belt slippage. (6) Loosened or disconnected wiring or connectors	Clean Change Change Replenish Re-adjust tension Check/Fasten
Engine oil pressure error (E-3) and engine stoppage.	(1) Engine oil shortage. (2) Clogged engine oil filter (3) Faulty oil pressure switch. (4) Loosened or disconnected wiring or connectors	Replenish engine oil Change Change Check/retighten
Charge error (A-5).	(1) Alternator trouble (2) Abnormality of the charging circuit (3) Belt loosened and/or cut	Check or change of alternator Check of the electrical system (charging circuit) Change
Discharge temperature sensor disconnection (E-6) or water temperature sensor disconnection (E-7) is displayed, and engine stoppage.	(1) Each sensor's wiring/connector loosen/come off. (2) Each sensor has error. (3) Each sensor disconnects.	Check/Fasten Disassemble/Check Repair and replace
Crank case pressure error (E-9) and engine stoppage.	(1) The freezing of the breather piping (2) Failure of the crank case internal pressure switch.	Defrost the piping with a heater, etc. Change
Engine monitor alarm lamp glows.	(1) Engine in trouble	※1

※1. After having found the cause with a service tool, it is necessary to take measures. Therefore, please contact your nearest distributor.

- Contact your nearest dealer if you find it difficult to repair by yourself.
- Refer to the engine operation manual for trouble concerning the engine.

5. Periodic Inspection/Maintenance

5.1 Important Items at Periodic Inspection and Maintenance or after Maintenance

This manual shows the inspection and maintenance intervals under normal operating conditions, not the warranty period. When using under severe environmental conditions or operating conditions, shorten the maintenance interval.

- Please wear protection implements, such as a helmet, protection glasses, earplugs, safety shoes, a glove, and a protection-against-dust mask, according to the contents of work for safety.
- Take care not to touch hot portions of the machine while inspecting during operation. Such parts as engine, exhaust manifold, exhaust pipe, muffler, radiator, oil cooler, air-end, pipe, separator receiver tank, and discharging pipe are especially hot, so never touch these parts, it will cause burning.

WARNING

Hang an “Under Maintenance” tag

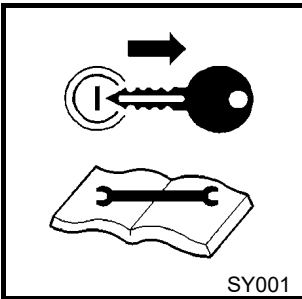

- Before starting inspection, make sure to turn the CONTROL POWER switch to “OFF”, and then lock the door on the front of the instrument panel, remove the key, and hang up a “Now Checking and under Maintenance” tag where it can be easily seen. The checker must keep the key during checking and maintenance.
- Remove the negative (-) side cable from the battery. If the above procedure is neglected, and another person starts operating the machine during check or maintenance, it could cause serious injury.

CAUTION

Prevention of oil separator from catching fire

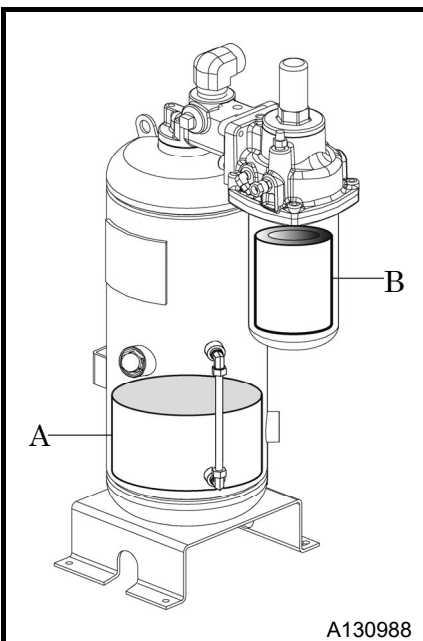

- Be sure to perform following periodic inspection and maintenance:
 - A. Check and change compressor oil quantity
 - B. Change oil separator

5. Periodic Inspection/Maintenance

IMPORTANT Uninstructed/unspecified work prohibited

- Be sure to use recommended fuel, oil, grease, and LLC (antifreeze).
- Do not disassemble or adjust engine, compressor air-end or part(s) for which inspection or maintenance is not referred to in this manual.
- Use genuine parts for replacement.
- Any breakdown, caused by using unapproved parts or by wrong handling, will be out of the scope of "WARRANTY".
- Keep the electrical components away from water or steam.
- Place a container or a pan underneath the oil port to catch waste liquid so that such liquid does not spill on the floor or inside the machine.
- Waste from machines contains harmful material. Do not dispose of such harmful fluids to the ground, rivers, lakes or ponds, and sea. It contaminates the environment.
- Be sure to follow the designated regulations when disposing of oil, fuel, LLC (antifreeze), filters, battery and other harmful things.

5.2 Inspection on Separator Receiver Tank

IMPORTANT Periodic inspection of separator receiver tank

- Be sure to carry out the following cleaning and inspection of the separator receiver tank at least once every year.

<Place to check>

- (1) Any damage found on the tank.
- (2) Any excessive wear found in the fastening bolts on the cover.
- (3) Any damage found to pipes and valves etc.

5. Periodic Inspection/Maintenance

5.3 Periodic Inspection List

(Unit: Hour)

Maintenance Items		Daily	250	300	500	1,000	2,000	3,000	8,000	Ref. Page
Compressor	Check compressor oil level	○								3-6
	Drain separator receiver tank	○								3-6
	Check for looseness in pipe connecting part, and wear and tear of pipe.	○								3-8
	Check oil, water, fuel and air leak	○								3-13
	Check functions of all instruments and devices	○								3-13
	Check and clean clogging of air filter element		○							5-9
	Change compressor oil			※1○	○					5-10
	Change compressor oil filter cartridge			※1○		○				5-11
	Change air filter element				○					5-11
	Clean strainer in the scavenging orifice				○					5-12
	Clean exterior of the oil cooler					○				5-13
	Change oil separator						☆●			5-16
	Change nylon tubes						☆●			5-16
	Change rubber hoses							★●		5-17
	Change O-ring of unloader							★●		5-17
	Change pressure regulator							●		5-17
	Check consumable parts of auto-relief valve.							★●		5-17
	Check consumable parts of vacuum-relief valve.							★●		5-18
	Performance check of pressure control valve							★●		5-18
	Check O-ring and piston of pressure control valve							★●		5-18
Check solenoid valve (Re-usable after check, if normal.)							●		5-19	
Change oil seal/bearing								●	5-20	

Items marked with a ○ are to be performed by the customer. For the following items or clauses marked with a ●, contact your nearest dealer because they require expert technical knowledge to perform.

The items or parts marked ※1 show that they should be replaced primarily.

- ※ The items or parts marked ☆ should be replaced every 2 years even if they are not in disorder within their periodical maintenance interval because their materials will change or become degraded as time passes. Also for the same reason, the parts marked ★ should be replaced every 3 years.
- ※ The indicated replacement periods are rough estimates. Depending on the usage conditions or environment, inspection/maintenance should be conducted earlier.
- ※ The above intervals of inspection and maintenance are respectively based on 1,000 hours of use per year.

5. Periodic Inspection/Maintenance

◎ Refer to engine operation manual for inspection and maintenance of an engine. For the details, contact our office nearby or distributor.

(Unit: Hour)

Maintenance Items		Daily	50	250	500	1,000	2,000	3,000	6,000	Ref. Page
Engine	Check engine oil level	○								3-4
	Check coolant level	○								3-5
	Check fuel	○								3-7
	Drain fuel tank condensate	○								3-7
	Check fuel filter for condensate	○								3-8
	Check looseness in pipe connectors, terminals and tear in wiring.	○								3-8
	Check belt tension	○								3-9
	Change engine oil		※1○	○						5-6
	Change engine oil filter cartridge		※1○	○						5-7
	Check battery electrolyte			○						5-7
	Check and clean clogging of air filter element			○						5-9
	Check specific gravity of battery electrolyte				○					5-7
	Change air filter element				○					5-11
	Change fuel filter element				○					5-12
	Check and clean supply pump strainer				○					5-13
	Clean the filter for fuel air-bleeding electromagnetic pump				○					5-13
	Clean exterior of the radiator					○				5-13
	Clean interior of radiator					●				5-14
	Change coolant (LLC)					☆○				5-15
	Clean inside of fuel tank						●			5-16
Change fuel hose						☆●			5-17	
Change radiator hoses							☆●		5-17	
Change wiring harness								●	5-20	

The items or parts marked ※1 show that they should be replaced primarily.

※ The items or parts marked ☆ should be replaced every 2 years even if they are not in disorder within their periodical maintenance interval because their materials will change or become degraded as time passes.

※ The indicated replacement periods are rough estimates. Depending on the usage conditions or environment, inspection/maintenance should be conducted earlier.

※ The above intervals of inspection and maintenance are respectively based on 1,000 hours of use per year.

(Unit: Hour)

Maintenance Items		Daily	250	300	500	1,000	2,000	3,000	Ref. Page
Undercarriage	Supply grease to trailer hub bearing.					○			5-14
	Supply grease to leaf spring pin.					○			5-14
	Check and confirm that drawbar is properly fixed with bolts properly, according to specified tightening torque.			○ Every 3 months					5-19
	Check and confirm that the bolts with which undercarriage brackets are fixed are properly tightened.			○ Every 3 months					5-19
	Check and confirm that the nuts with which tires are fixed are properly tightened.			○ Every 3 months					5-20

5. Periodic Inspection/Maintenance

5.4 Replacement Parts Schedule

Part numbers change upon modification. For replacement of parts, contact your nearest dealer to verify the part number is correct or applicable.

Part Name		Part Number	Quantity
Engine oil filter cartridge		ISUZU 894456-7412	1
Air filter element	Compressor air-end	32143 11800	1
	for engine side	32143 11800	1
Compressor oil filter cartridge		37438 08900	1
O-ring for filler cap		03402 25030	1
Fuel filter element		43543 01000 ISUZU 898143-0411	1
Gasket kit for fuel air-bleeding electromagnetic pump		ISUZU 898071-4040	1 set
Solenoid valve for starting unload		46811 30000	1
Oil separator element		34224 03000	1
Pressure control valve	O-ring [A]	03402 15075	1
	O-ring [B]	03402 25032	1
	Piston	35303 03300	1
Pressure regulator		36400 19000	1
Engine supply pump strainer [A]		ISUZU 898074-9550	1
Gasket for engine supply pump strainer [B]		ISUZU 109630-0830	3
Gasket for engine supply pump strainer [C]		ISUZU 109630-0850	3
Belt		ISUZU 898095-3350	1

5. Periodic Inspection/Maintenance

5.5 Maintenance Items

5.5.1 Change engine oil

At 50 hours for the first change and at every 250 hours thereafter

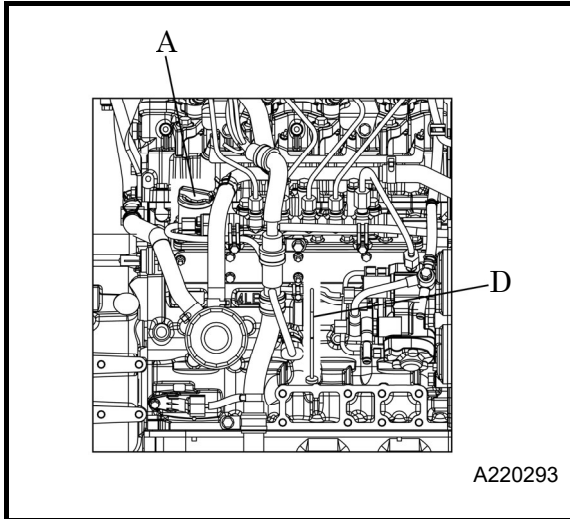

<Procedures>

1. Remove the cap of engine oil filler port [A], and remove the drain plug [B] fixed outside, and then open the drain valve [C] fixed inside to drain oil.
2. When the oil is drained, close the drain valve [C], reinsert the drain plug [B] and pour in engine oil in from the engine oil filler port [A].

[Oil capacity : Approx. 2.38gal. (9L)]

3. After supplying oil, pull out the oil level gauge [D] and wipe it out.
4. Then, re-insert the oil level gauge fully and pull it out again. If the oil level gauge shows the oil level between upper limit and lower limit, it is normal.
5. After finishing the oil supply, tighten the cap of engine oil filler port [A] and the oil level gauge [D] firmly.

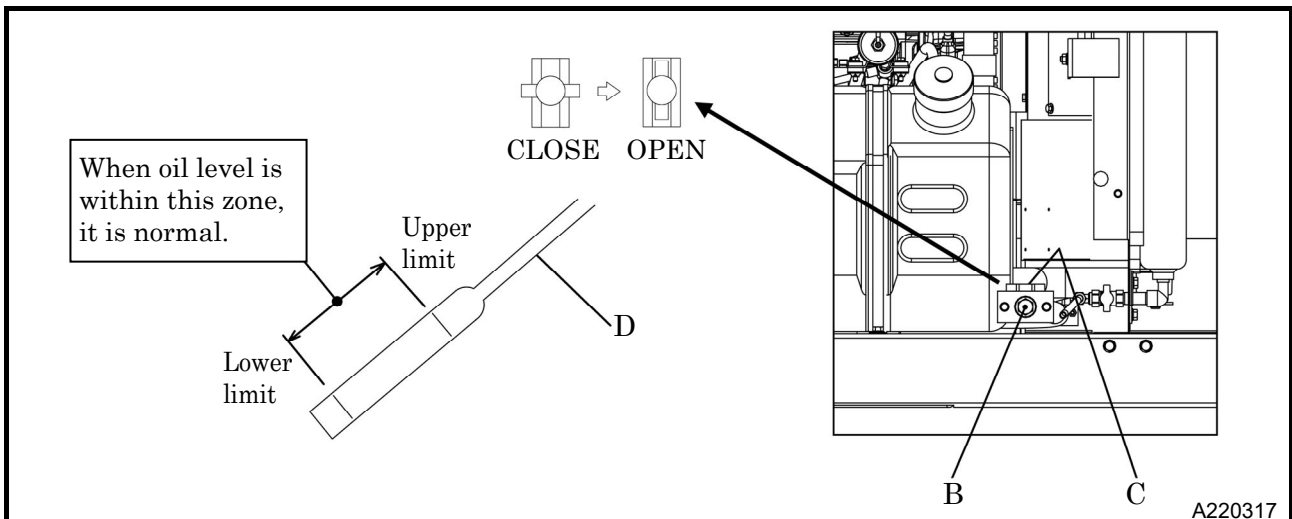

CAUTION

Caution in filling or discharging engine oil

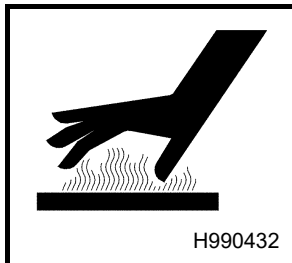

- After stopping the engine, wait of 10 minutes or more until the engine oil cools off. Then check the level of the engine oil, or refill or drain the oil.
- Engine oil is very hot and highly pressurized during and just after operating. Hot oil may spray out and cause injury.
- Never overfill the engine oil above the proper level. Too much oil can cause white smoke out of the exhaust, and it can damage and harm the engine.

IMPORTANT

- Follow the designated regulations to dispose of engine oil.

5. Periodic Inspection/Maintenance

5.5.2 Change engine oil filter cartridge

At 50 hours for the first change and at every 250 hours thereafter

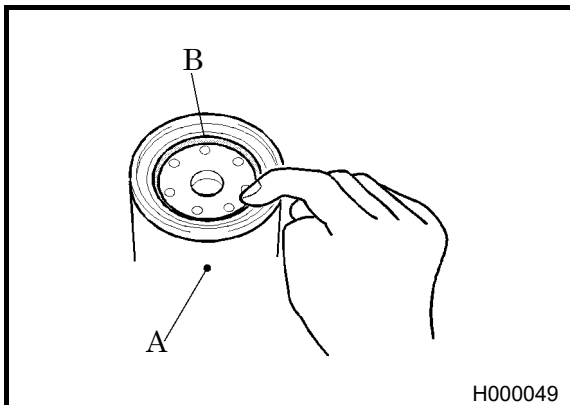

<Procedures>

1. Remove the oil filter cartridge [A], using a filter wrench.
2. Screw in the new oil filter cartridge [A] with the packing [B] coated slightly with oil.
(For part number, See 5.4)
3. After the packing touches the sealing face, tighten another 1 times with a filter wrench.
4. After installing the oil filter cartridge, check it for any leak during operation.

5.5.3 Check battery electrolyte and specific gravity of battery electrolyte

Battery electrolyte: every 250 hours

Specific gravity of battery electrolyte: every 500 hours

If there is an engine starting issue due to battery discharge, follow the procedure below:

- **Ordinary type battery:**

Check the amount of battery fluid and if it is not within specification, add distilled water.

Measure specific gravity of battery electrolyte, and if it shows below 1.24, recharge the battery immediately. **(See 5.5.4)**

- **Enclosed type battery:**

Check the indicator on top of the battery.

If the indicator shows that charge is needed, recharge the battery immediately.

If specific gravity of battery electrolyte does not rise in spite of replenishing distilled water or charging battery, be sure to replace battery with new one quickly.

5. Periodic Inspection/Maintenance





5.5.4 Maintenance of Battery

Battery may generate hydrogen gas and can explode. Therefore, recharging should be done in a well-ventilated place.

- Do not check the battery by short-circuiting the positive and negative terminals with a piece of metal.
- Never operate the machine nor charge the batteries with the battery liquid level being kept lower than the lower level.

Continuing operation at this lower level will cause deterioration of such parts as pole plates etc., and also it may cause explosion as well as reduction of battery life. Add distilled water so that the liquid level may reach the middle level between the “UPPER LEVEL” and “LOWER LEVEL” without any delay.

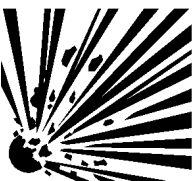
- Wear protective gloves and safety glasses when handling the battery.
 - When such battery electrolyte contacts your clothes or skin, wash it away with large amount of water immediately.
 - If the battery electrolyte gets into your eyes, wash it away immediately with plenty of water and see a doctor at once, because it is feared that eyesight might be lost.

 WARNING Handling the Battery	
 D004	<ul style="list-style-type: none">● Keep flames away from battery.● Keep sparks, matches, cigarettes, and other fire sources away from the battery.● Do not charge the frozen battery. Otherwise it may explode. If the battery is frozen, warm it up until the battery temperature becomes 61°F to 86°F (16°C to 30°C), and then recharge.● Battery electrolyte is dilute sulfuric acid. In case of mishandling, it could cause skin burning.● Dispose of battery observing local regulations.
 W010	
 TR0093	

[Charge battery]

- Use the battery charger after make sure to confirm whether it's fulfill a condition with the battery you charge.
- Disconnect the cable between battery and the machine, and charge the battery with a 12V battery charger.
- Be sure not to connect (+) and (-) terminals backwards.

5. Periodic Inspection/Maintenance

[How to use booster cable]

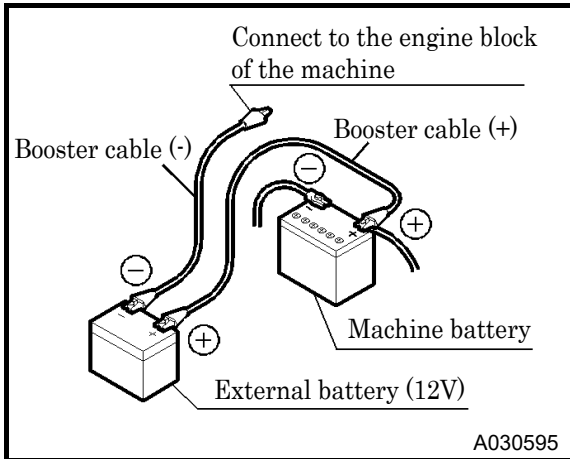

<Procedure for using a booster cable>

1. Stop the engine.
2. Connect one end of the (+) booster cable to the (+) terminal of the machine battery.
3. Connect the other end of the (+) booster cable to the (+) terminal of the external battery.
4. Connect one end of the (-) booster cable to the (-) terminal of the external battery.
5. Connect the other end of the (-) booster cable to the engine block of the machine.
6. Start up the engine.
7. Disconnect the booster cable by following the procedure back in the reverse order.



CAUTION

Do not reverse the cable connection

- When a booster cable has to be used or when cables are connected again after an battery is replaced, be careful not to connect (+) and (-) terminals backwards. Such wrong-connection will cause spark and damage to each component.

5.5.5 Check and clean clogging of air filter element

Every 250 hours

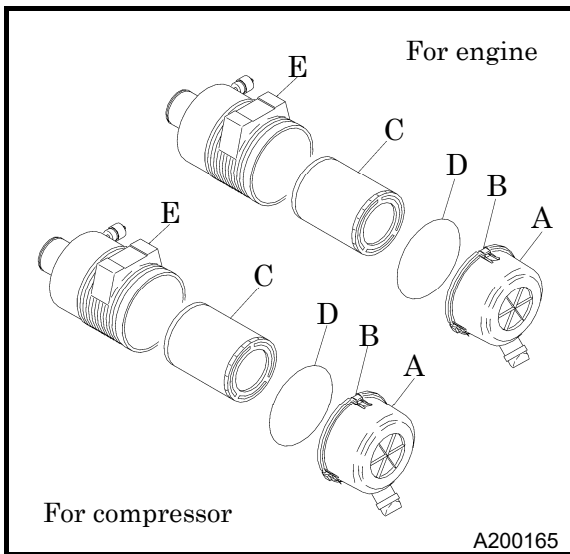

<Procedures>

1. Loosen the cap fix latch [B] at cap [A], then remove cap and clean inside.
 2. Remove the element [C], and clean it.
 3. When installing the cap after it is cleaned, hold the case [E] securely by hand so that O-ring [D] may not protrude from it, and retighten it after checking and confirming that the latch hook for fixing the cap is engaged to the case.
- If the element is found heavily dusty, replace it with a new one. **(For part number, See 5.4)**

IMPORTANT

- When an element that is clogged or has holes or cracks is used, dust or foreign material will get in the engine. This causes accelerated wear in each sliding part of the engine. Be sure to make daily check and cleaning so that the life of the engine will not be shortened.

5. Periodic Inspection/Maintenance

5.5.6 Change compressor oil

At 300 hours for the first change and at every 500 hours thereafter

- For prevention of fire caused due to deteriorated oil separator, in principle change of compressor oil is to be performed in accordance with the schedule mentioned in the regular maintenance table. However, it is heavily influenced by operation conditions and environmental conditions. If it has been found more dirty and corrupted, it should be changed.
- If machine is continuously operated in such bad conditions, it could damage bearings and degraded oil sticks oil separator to cause accumulated oxidation heat of reaction to lead oil separator fire. For this reason, regular maintenance work should be done surely and perfectly.
- Before replacing the compressor oil, stop the machine and wait for a sufficient period of time (about two or three minutes) to allow the oil to settle in the machine.

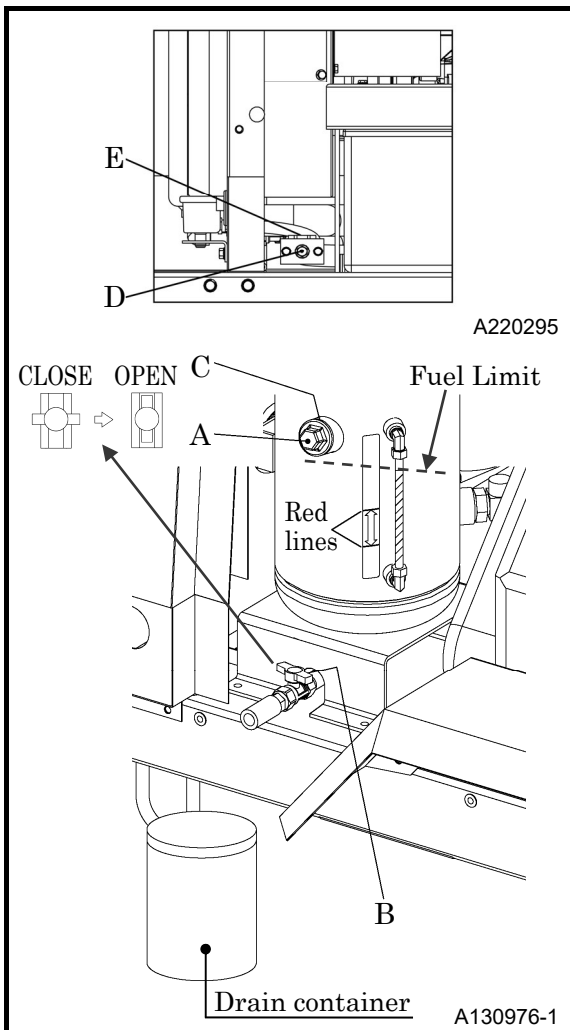

<Procedures>

1. After the machine has stopped and pressure inside the separator receiver tank has been completely released as much time passed, remove the oil filler cap [A] and open the drain valve [B] to drain the residual oil.
2. Remove the drain plug [D] of the oil cooler and open the drain valve [E] to drain the compressor oil accumulated in the cooler.
3. After draining compressor oil, fully close the drain valve [B] and [E], reinsert the drain plugs [D].
4. Fill the tank with new compressor oil up to the height indicated by the dotted line (Fuel Limit). Then, close filler cap [A]. Inspect O-ring [F] of filler cap [A]. and replace it with a new one if any hardening or damage is found.
(For part number, See 5.4)
5. After starting operation, check and confirm that oil level is within red lines of oil level gauge.

Quantity of oil between the red lines	Approx. 0.45gal. (1.7L)
Quantity of change oil	Approx. 3.96gal. (15L)

IMPORTANT

- Mixture of different brands compressor oil could cause an increase of viscosity and make compressor oil sticky. In the worst case, it could cause sticking trouble of compressor air-end “Compressor air-end will not turn”. Also repairing of such air-end needs expensive cost. Therefore, be sure to avoid mixing different brands oil. In case compressor oil brand in use has to be unavoidably changed, it is absolutely necessary to completely clean up the interior of compressor air-end. In such a case, contact your nearest dealer.
- Follow the designated regulations to dispose of compressor oil.

5. Periodic Inspection/Maintenance

5.5.7 Change compressor oil filter cartridge

At 300 hours for the first change and at every 1,000 hours thereafter

Be sure to use genuine oil filter cartridge.

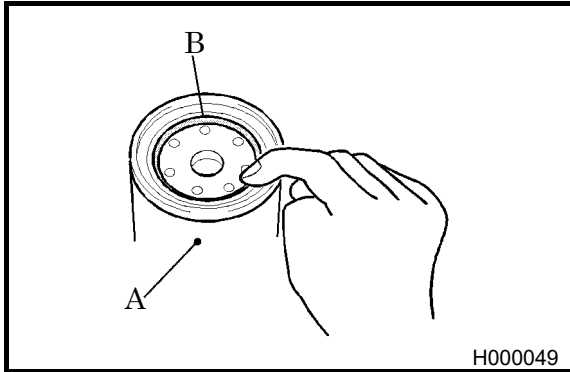

<Procedures>

1. Remove the oil filter cartridge [A], using a filter wrench.
2. Screw in the new oil filter cartridge [A] with the packing [B] coated slightly with oil.
(For part number, See 5.4)
3. After the packing touches the sealing face, tighten another 3/4 to 1 turn with a filter wrench.
4. After installing the oil filter cartridge, check it for any leak during operation.

IMPORTANT

- Poor quality oil filter cartridge do not trap dust sufficiently and will cause damage to the bearings in a short period. Be sure to use genuine parts.

5.5.8 Change air filter element

Every 500 hours

Be sure to use genuine air filter element.

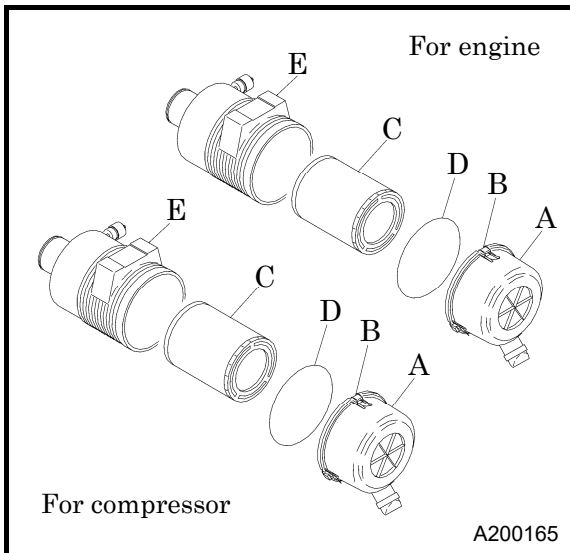

<Procedures>

1. Loosen the cap fix latch [B] at cap [A], then remove cap and clean inside.
 2. Remove element [C] and replace with new one.
(For part number, See 5.4)
 3. When installing the cap [A], surely push the O-ring [D] to the case [E] with a hand and then tighten it after checking and confirming that the hook of the cap fixing latch is caught in the case.
- When used or operated under bad conditions, it is better to remove all the elements, check them, clean them and replace them earlier before the intervals listed in maintenance table, if they are found difficult to be repaired.

IMPORTANT

- The air filter is an important part which is crucial to your machine's performance and life. Be sure to use genuine parts.

5. Periodic Inspection/Maintenance

5.5.9 Clean strainer in the scavenging orifice

Every 500 hours

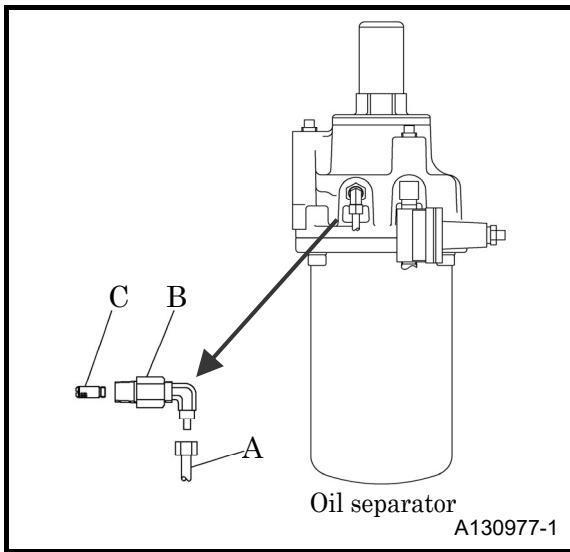

<Procedures>

1. Remove the nylon tube [A].
2. Remove the bushing [B] from the oil separator.
3. Remove the strainer [C] screwed into the bushing.
4. Wash the removed strainer in diesel oil and blow out "dust" by air blowing.
5. After finishing the cleaning, install the strainer again in the reverse procedure.

5.5.10 Change fuel filter element

Every 500 hours

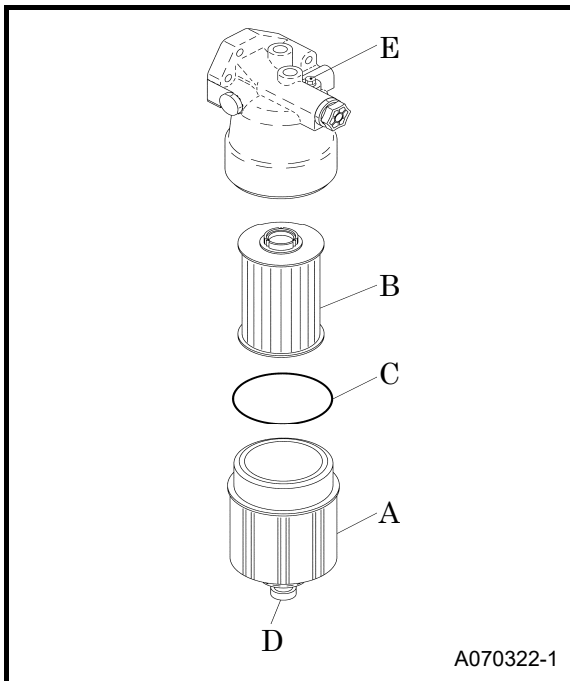

<Procedures>

1. Loosen the drain plug [D] and air bleeding plug [E] to discharge the fuel inside the filter. After draining completed, tighten the drain plug [D] and air bleeding plug [E] securely.
2. Use the special filter wrench to remove the filter case [A].
3. Replace the O-ring [C] with new one and place new element [B] in the case. Thinly apply the fuel on the O-ring, and screw in the element.
(For part number, See 5.4)
4. After the packing touches the sealing face, tighten it using a filter wrench.
5. Bleed the air from the fuel. **(See 3.4.6)**
 - After installing the element[B], check it for any leak during operation.
 - For details of replacement, refer to the engine operation manual.

5. Periodic Inspection/Maintenance

5.5.11 Check and clean supply pump strainer

Every 500 hours

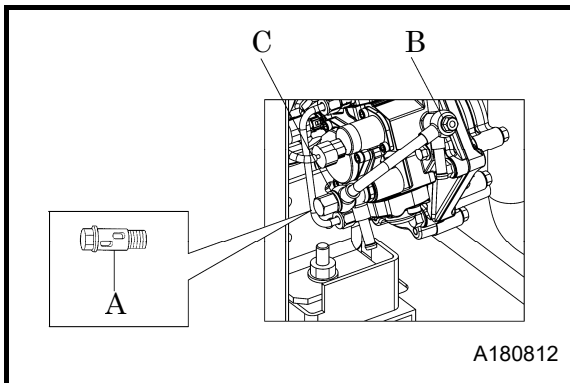

- Loosen the supply pump strainer [A] (joint bolt built-in type) and remove it. After washing it with diesel oil, blow dust and dirt off with high pressure air. Replace the gasket [B] and [C] as well.

(For part number, See 5.4)

- In case the conditions of lowered engine power and engine stop will not be improved even after the supply pump strainer [A] (joint bolt built-in type) has been cleaned, it should be replaced.

(For part number, See 5.4)

CAUTION

- Do not pull out the supply pump strainer inside as it cannot be disassembled.
(For details, refer to the engine operation manual.)

5.5.12 Clean the filter for fuel air-bleeding electromagnetic pump

Every 500 hours

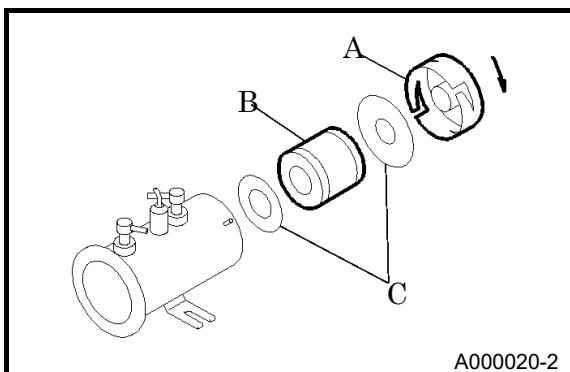

- Turn the cap [A] to the left to remove and clean filter [B] inside.
- Replace the gasket [C] whenever the filter [B] is removed. (For part number, See 5.4)
- Prepare a container as the fuel inside may spill out.

5.5.13 Clean exterior of the radiator • oil cooler

Every 1,000 hours

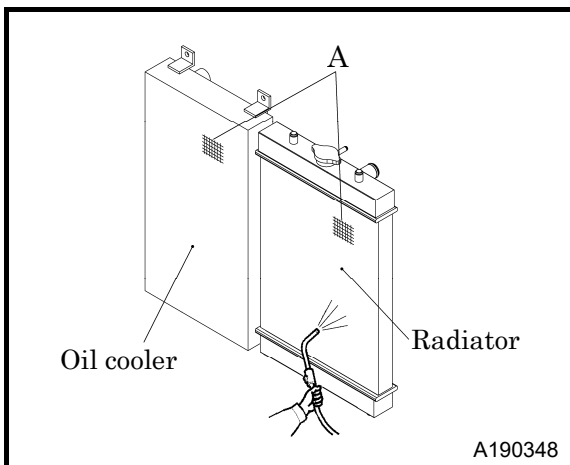

- When the fin tubes diaphragm [A], of a radiator, and an oil cooler are clogged with dust or other foreign materials, the heat exchange efficiency drops and this will raise coolant temperature and discharge air temperature. These tubes and fins should be cleaned depending on the state of clogged tubes diaphragm, even before maintenance schedule.
- Do not use a high pressure washer to protect fin tubes from being damaged.
- Take steam cleaning with removing cooler when there is a lot of dirt.

5. Periodic Inspection/Maintenance

5.5.14 Clean interior of radiator

Every 1,000 hours

- When the inside of a radiator and water conduits of an engine are dirty with scale and rust, its cooling efficiency will be deteriorated. Clean the interiors of such components periodically.
- When cleaning it, contact your nearest dealer because it requires expert technical knowledge.

5.5.15 Supply grease to trailer hub bearing

Every 1,000 hours

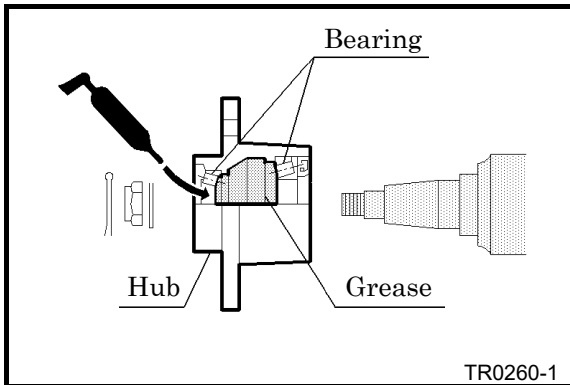

- When replenishing grease to the trailer hub bearing, contact your nearest dealer.

Grease: Chassis grease

5.5.16 Supply grease to leaf spring pin

Every 1,000 hours

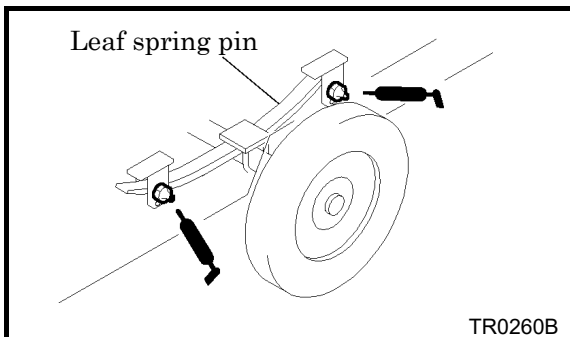

- When replenishing grease to the leaf spring pin, contact your nearest dealer.

Grease: Chassis grease

5. Periodic Inspection/Maintenance

5.5.17 Change coolant

1,000 hours or every 2 years

Be sure to stop the engine and let the coolant water sufficiently cool down before changing it.

<Procedures>

1. Remove the inlet cover [A], the radiator cap [B] on the top of the radiator, and the drain plug [C] outside the machine. Next, open the drain valve [D] to drain the coolant.
 2. Be sure to also open the drain plug [E] on the engine cylinder block for drainage.
 3. Drain the coolant in the reserve tank [F] .
 4. After the drainage of the coolant is completed, close drain valve [D] and drain plug [C], and then fasten drain valve [E] on the engine side. Replenish coolant so that it reaches the opening of the radiator inlet. Do not forget to pour in cooling water up to the MAX level of the reserve tank [F] .
 5. After refilling coolant, securely attach the radiator cap [B] and the reserve tank [F] cap and operate the machine for about 5 minutes with no load.
 6. Stop the machine, wait until the coolant has cooled down, and then check the coolant level.
 7. If the coolant level is too low, replenish the coolant.
- Refer to section 3.3.2 for reserve tank capacity details.

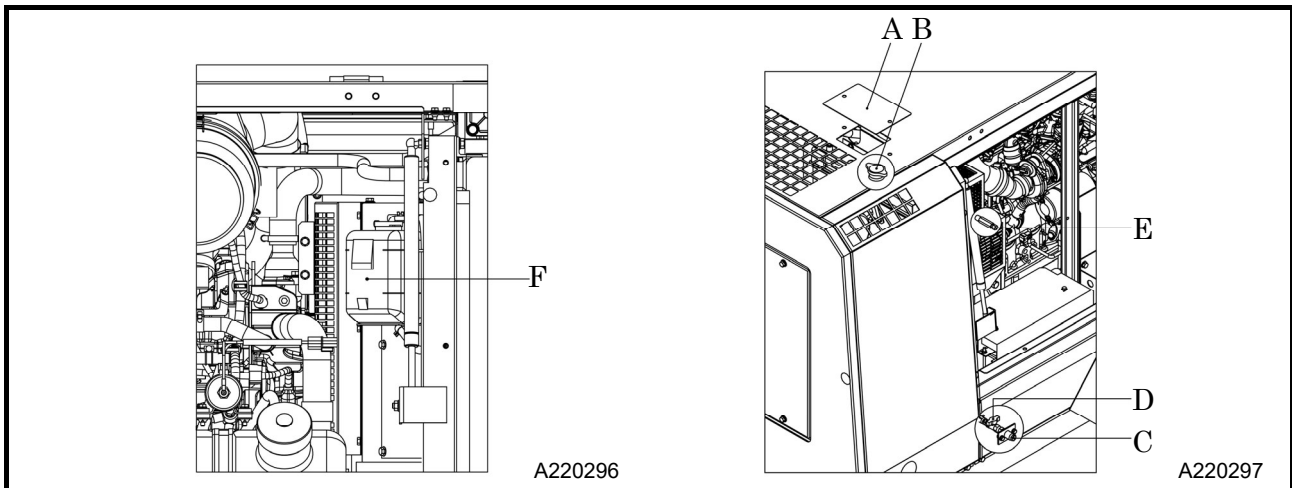

CAUTION Caution when changing coolant

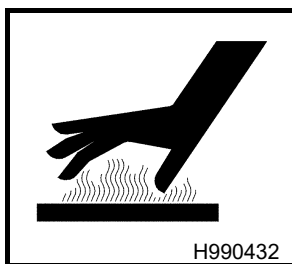

- When removing the radiator cap, lightly turn it and release the internal pressure without completely opening it once the first stage lock is released. After confirming that the internal pressure has been released, turn it while pushing in until the second stage lock is released. If this procedure is neglected, its inner pressure can blow off the radiator cap, and steam jetting out of the radiator may cause scalding burns.
- LLC (antifreeze) is a toxic.
- In case of accidental ingestion, do not force vomiting and seek medical attention immediately.
- In case of contact with eyes, rinse with plenty of water and seek medical attention.
- When storing LLC (antifreeze), label it as LLC (antifreeze), seal it, and keep it out of reach of children.
- Beware of flames.

IMPORTANT

- Follow the designated regulations to dispose of LLC (antifreeze).

5. Periodic Inspection/Maintenance

5.5.18 Change oil separator

2,000 hours or every 2 years

- Even before the periodic interval time of replacement, replace the oil separator element whenever the oil consumption increases and also oil is found mixed in the discharge air.
(For part number, See 5.4)
- When consumption of the oil is still unusual even after cleaning strainer in the scavenging orifice (See 5.5.9), change the oil separator element with a new one.
- When replacing oil separator, contact your nearest dealer because it requires expert technical knowledge.

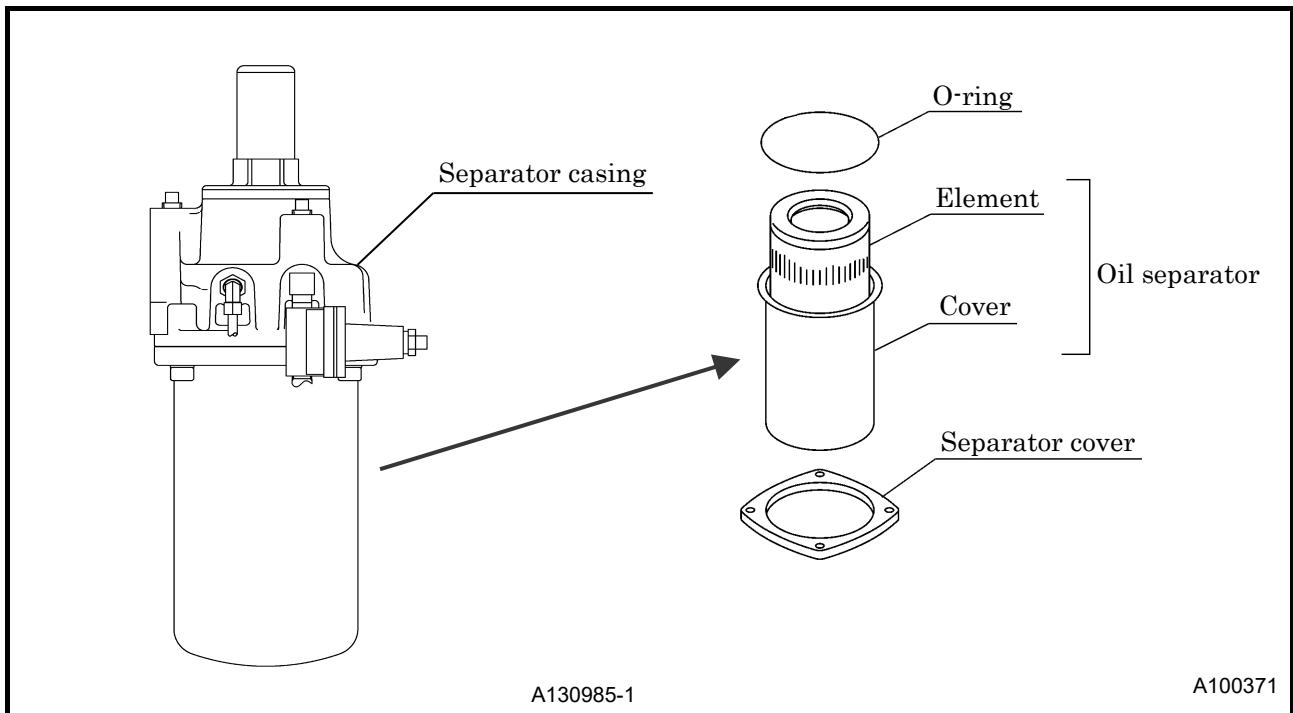

IMPORTANT

- When changing the oil separator, both cover and element must be replaced with new ones.

5.5.19 Clean inside of fuel tank

Every 2,000 hours

When cleaning inside of fuel tank it, contact your nearest dealer because technical knowledge is required.

5.5.20 Change nylon tubes

2,000 hours or every 2 years

Replace nylon tubes used for the oil and air piping's. When replacing it, contact your nearest dealer because it requires expert technical knowledge.

5. Periodic Inspection/Maintenance

5.5.21 Change fuel hose

2,000 hours or every 2 years

In case various rubber hoses for fuel system and engine lubrication system are hardened or deteriorated, replace them even before the specified replacement time.

When replacing it, contact your nearest dealer because it requires expert technical knowledge.

5.5.22 Change rubber hoses

3,000 hours or every 3 years

Check hoses used for oil piping for any crack or tear, and replace when an abnormality is found.

When replacing it, contact your nearest dealer because it requires expert technical knowledge.

5.5.23 Change radiator hoses

3,000 hours or every 2 years

When any crack or wear is found on the hoses, change it even before the scheduled time.

When replacing it, contact your nearest dealer because it requires expert technical knowledge.

5.5.24 Change O-ring of unloader

3,000 hours or every 3 years

When replacing it, contact your nearest dealer because it requires expert technical knowledge.

5.5.25 Change pressure regulator

Every 3,000 hours

When replacing it, contact your nearest dealer because it requires expert technical knowledge.

(For part number, See 5.4)

5.5.26 Check consumable parts of auto-relief valve

3,000 hours or every 3 years

When replacing it, contact your nearest dealer because it requires expert technical knowledge.

5. Periodic Inspection/Maintenance

5.5.27 Check consumable parts of vacuum-relief valve

3,000 hours or every 3 years

When replacing it, contact your nearest dealer because it requires expert technical knowledge.

5.5.28 Performance check of pressure control valve

3,000 hours or every 3 years

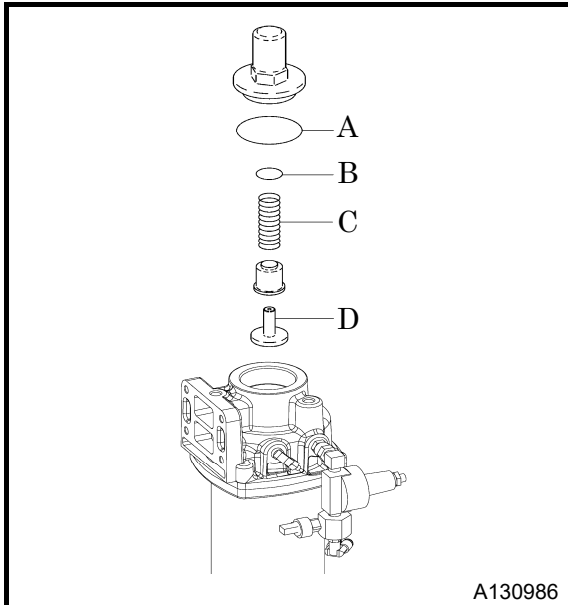

<Procedures>

1. When the service valve is fully opened during operation, confirm that the pressure gauge on the instrument panel indicates 58 psi (4 bar).
2. When the pressure is lower than 58psi (4bar), replace spring [C] with a new one.
(For part number, See 5.4)
3. When the indicator shows excessively higher pressure, you will find that the piston does not move smoothly due to foreign material and rust stuck inside valve. In such a case, disassemble the component for checking and cleaning.
 - When replacing it, contact your nearest dealer because it requires expert technical knowledge.

IMPORTANT

- When reassembling, apply sufficient grease to O-ring Slot/O-ring and sliding surface. Use CALTEX MULTIFAK EP1 grease or equivalent. Grease of poor quality will deteriorate the material.

5.5.29 Check O-ring and piston of pressure control valve

3,000 hours or every 3 years

After disassembling and cleaning pressure control valve, check O ring [A], [B] and piston [D]. When the rubber of these parts is found hardened, or damaged, replace them. **(For part number, See 5.4)** When replacing it, contact your nearest dealer because it requires expert technical knowledge.

5. Periodic Inspection/Maintenance

5.5.30 Check solenoid valve

Every 3,000 hours

When replacing it, contact your nearest dealer because it requires expert technical knowledge.

5.5.31 Check and confirm that drawbar is properly fixed with bolts properly, according to specified tightening torque

Every 3 months

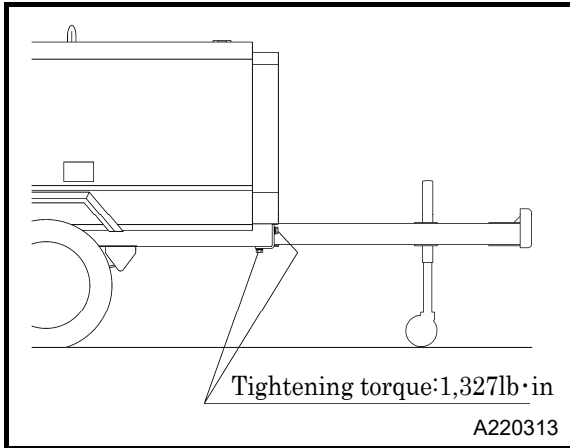

- Check and confirm once every three months that the bolts with which drawbar is fixed are not loosened. (8 points)
- If it is found that specified tightening torque of clamped bolts drops to a lesser value, retighten them to correct specified value.

5.5.32 Check and confirm that the bolts with which undercarriage brackets are fixed are properly tightened.

Every 3 months

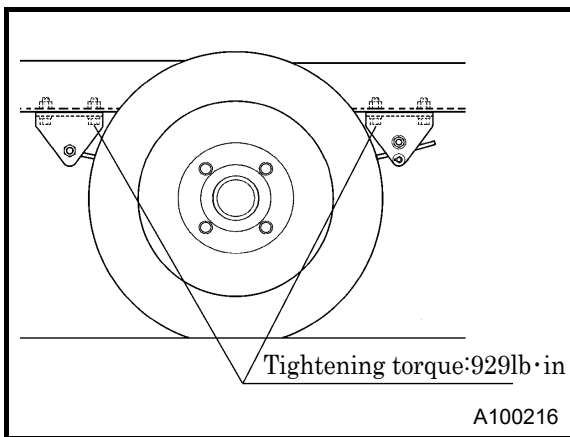

- Check and confirm once every three months that there is no looseness in tightening bolts. (8 points)
- If it is found that specified tightening torque of clamped bolts drops to a lesser value, retighten them to correct specified value.

5. Periodic Inspection/Maintenance

5.5.33 Check and confirm that the nuts with which tires are fixed are properly tightened

Every 3 months

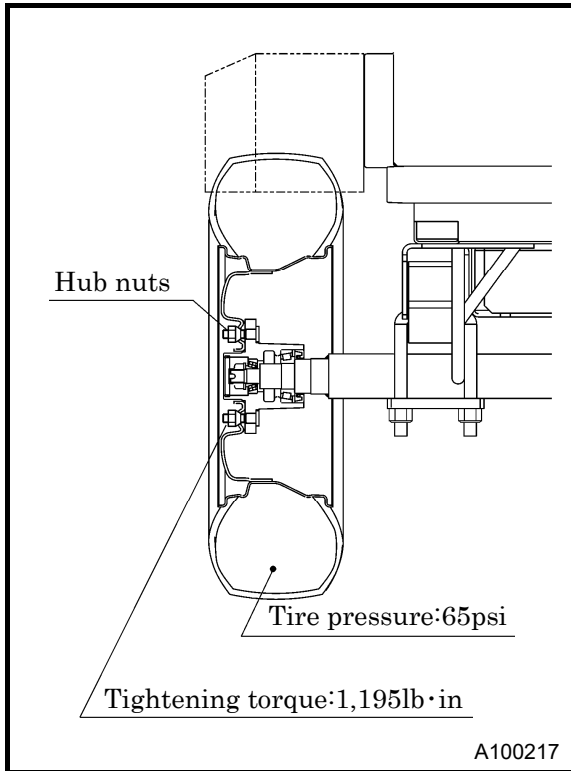

- Check and confirm once every three months that hub nuts with which tires are fixed are not loosened. (10 points)
- If it is found that specified tightening torque of clamped bolts drops to a lesser value, retighten them to correct specified value.

5.5.34 Change wiring harness

Every 6,000 hours

When replacing it, contact your nearest dealer because it requires expert technical knowledge.

5.5.35 Change oil seal/bearing

Every 8,000 hours

When replacing it, contact your nearest dealer because it requires expert technical knowledge.

6. Storage and Disposal

6.1 Preparation for Long-term Storage

When storing for more than half a year without using the machine, perform the following measures and store it in a dry place with little dust.

- Put the machine in a temporary cabin if it is stored outside. Avoid leaving the machine outside with a sheet directly on the paint for a long period of time, as this may cause rusting.
- Perform the following measures at least once every three months.

<Procedures>

1. Drain existing lubricant from the engine oil pan. Pour new lubricant in the engine to clean its inside. After running it for a while, drain it again.
2. Completely charge the battery and disconnect grounding wires. If possible, remove the battery from the machine and store it in a dry place. Charge the battery at least once every month.
3. Drain coolant and fuel from the machine.
4. Seal the engine, air-intake port and other openings like the muffler with a vinyl sheet, packing tape, etc., to prevent moisture and dust from entering the machine.
5. Be sure to repair any breakdowns and maintain the machine so that it will be ready for the next operation.

6.2 Disposal of Product

When disposing of this machine, first drain the cooling water and oils.
If you require any additional information, contact your nearest dealer.

7. Specifications

7.1 Specifications

Description		PDS185S-6EZ1	
COMPRESSOR	Type	Single-stage oil cooled, screw type compressor	
	Free air delivery	cfm(m ³ /min)	185(5.2)
	Working pressure	psi(bar)	100(6.9)
	ENG.SPEED (full load)	min ⁻¹	2,400
	ENG.SPEED (unload)	min ⁻¹	1,250
	Lubricating system		Forced Lubrication by compressed pressure
	Driving system		Direct driving with gear coupling
	Separator receiver tank capacity	cu in.(L)	1,220(20)
	Lubricating oil capacity	gal.(L)	3.96(15)
ENGINE	Model		ISUZU 4LE2T
	Type		4 Cycle, water cooled, direct injection, Turbocharged
	Aftertreatment		DOC
	Cylinder quantity - Cylinder diameter × Cylinder stroke	in.(mm)	4-3.35in.×3.78in. (4-85mm×96mm)
	Total displacement	cu in.(L)	133(2.179)
	Rated output (GROSS)	HP(kW)/min ⁻¹	48.3(36.0)/2,400
	Rated output (NET)	HP(kW)/min ⁻¹	45.2(33.7)/2,400
	Lubricating oil capacity	gal.(L)	2.22(8.4)
	Coolant capacity (including radiator)	gal.(L)	2.38(9.0)
	Battery		95D31R×1(12V)
	Fuel tank capacity	gal.(L)	23.8(90)
DIMENSION · MASS	Overall length	in.(mm)	77.8(1,975)
	Overall length only for bonnet	in.(mm)	75.2(1,910)
	Overall width	in.(mm)	66.3(1,685)
	Overall height	in.(mm)	42.3(1,075)
	Net dry mass	lb.(kg)	1,731(785)
	Operating mass	lb.(kg)	1,951(885)

7. Specifications

7.2 Exterior drawing

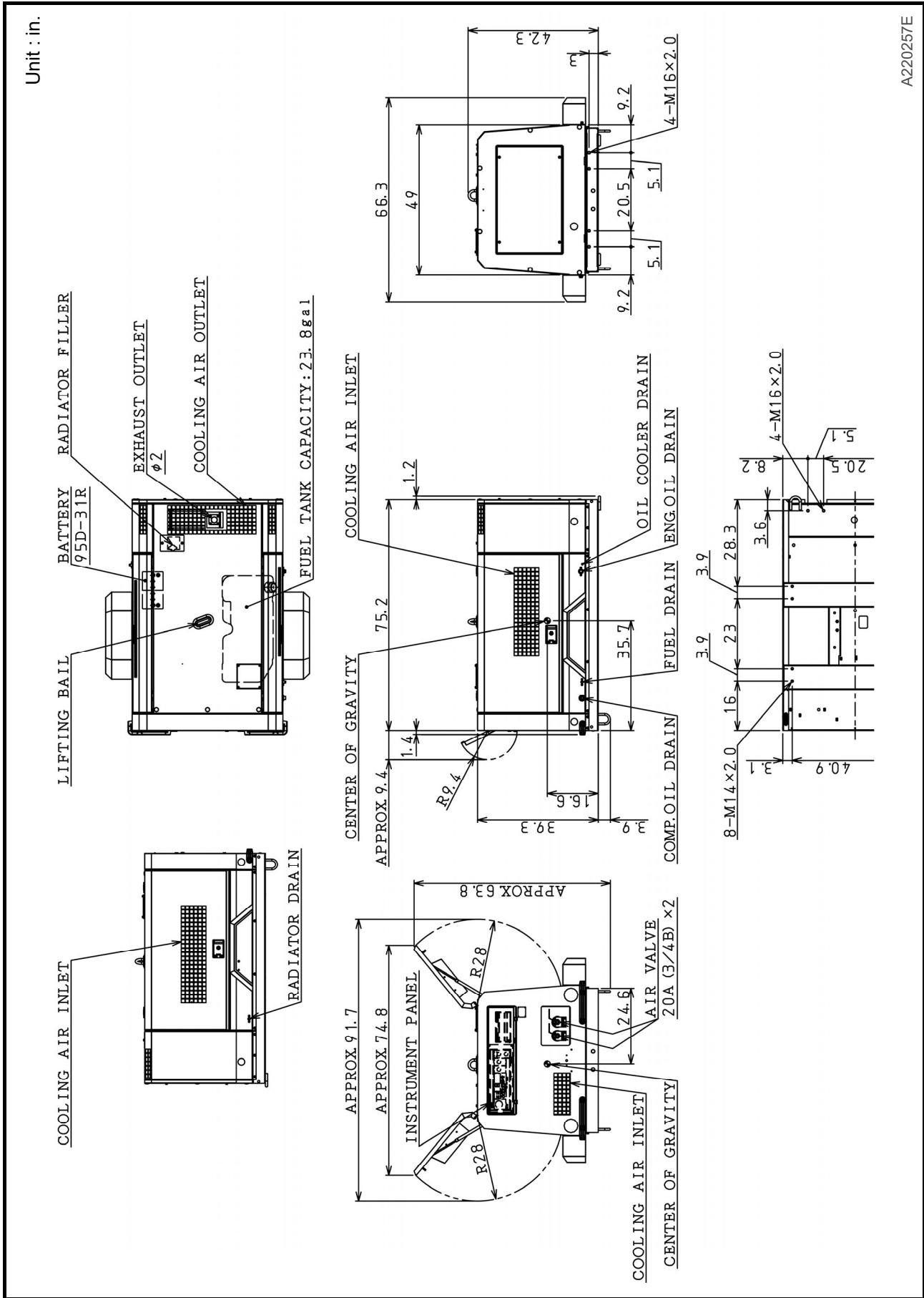

A220257E

7. Specifications

Unit : mm

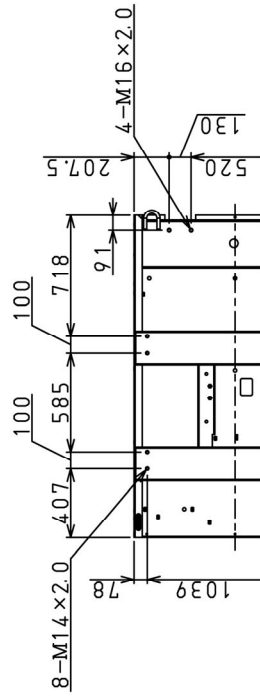
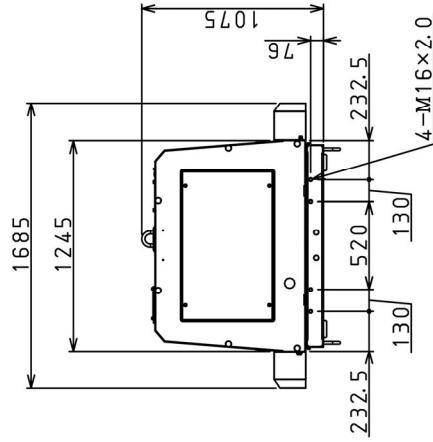
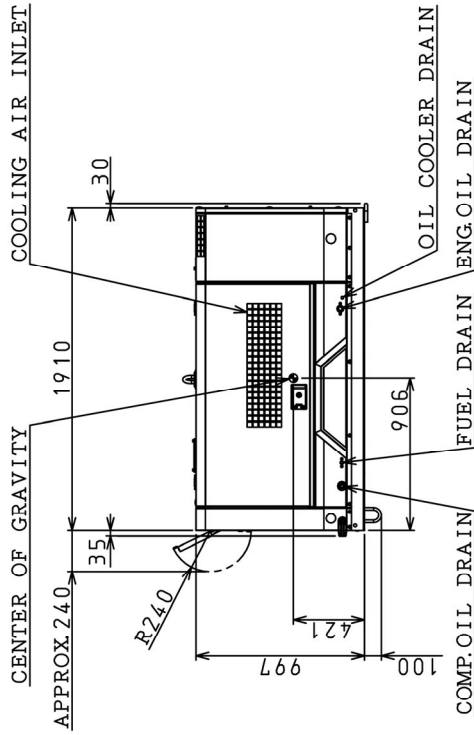
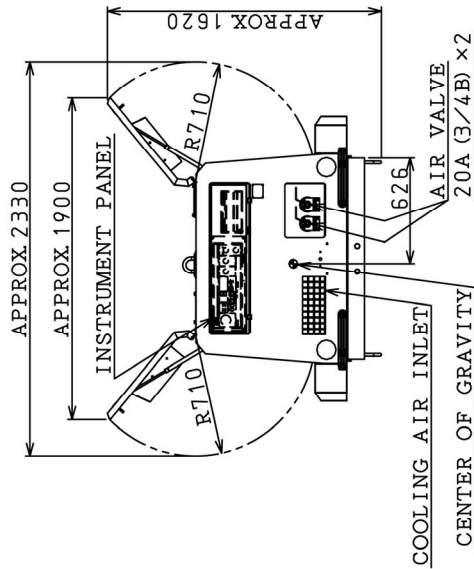
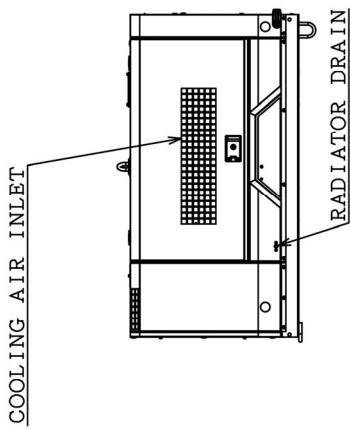
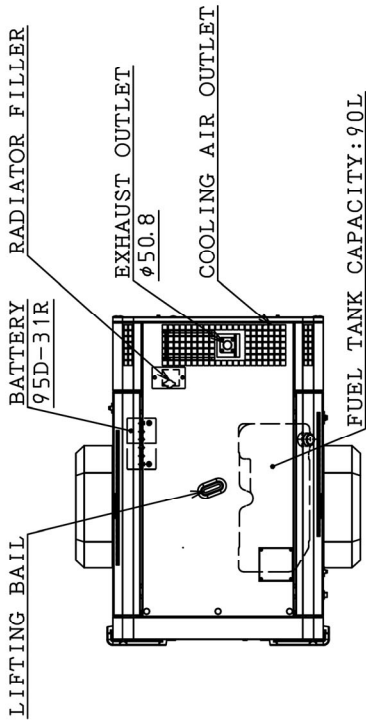

A220258E

7. Specifications

7.3 Wiring Diagram

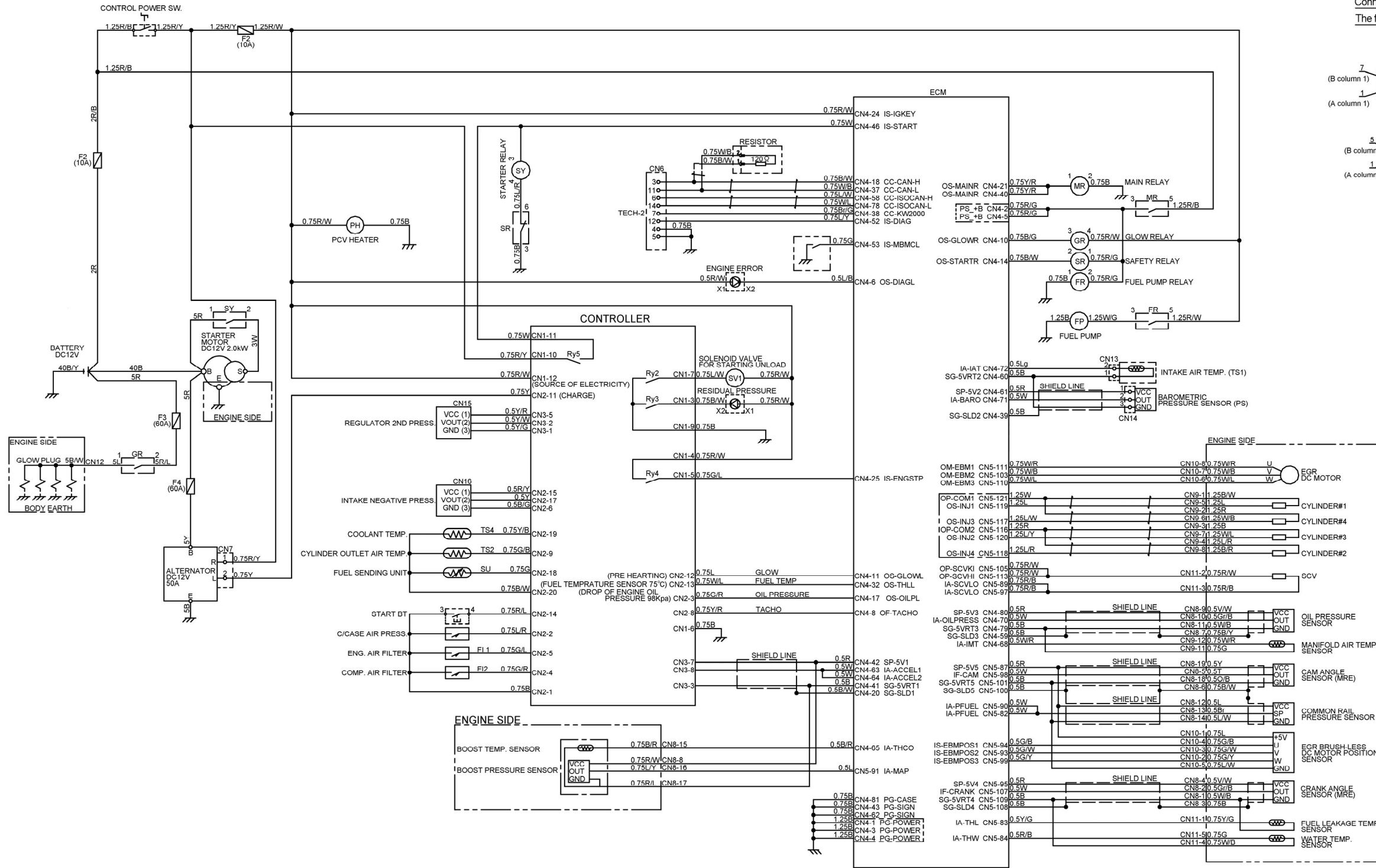

Connector terminal arrangement
The following arrangement is seen from the side of the connector inserting port.

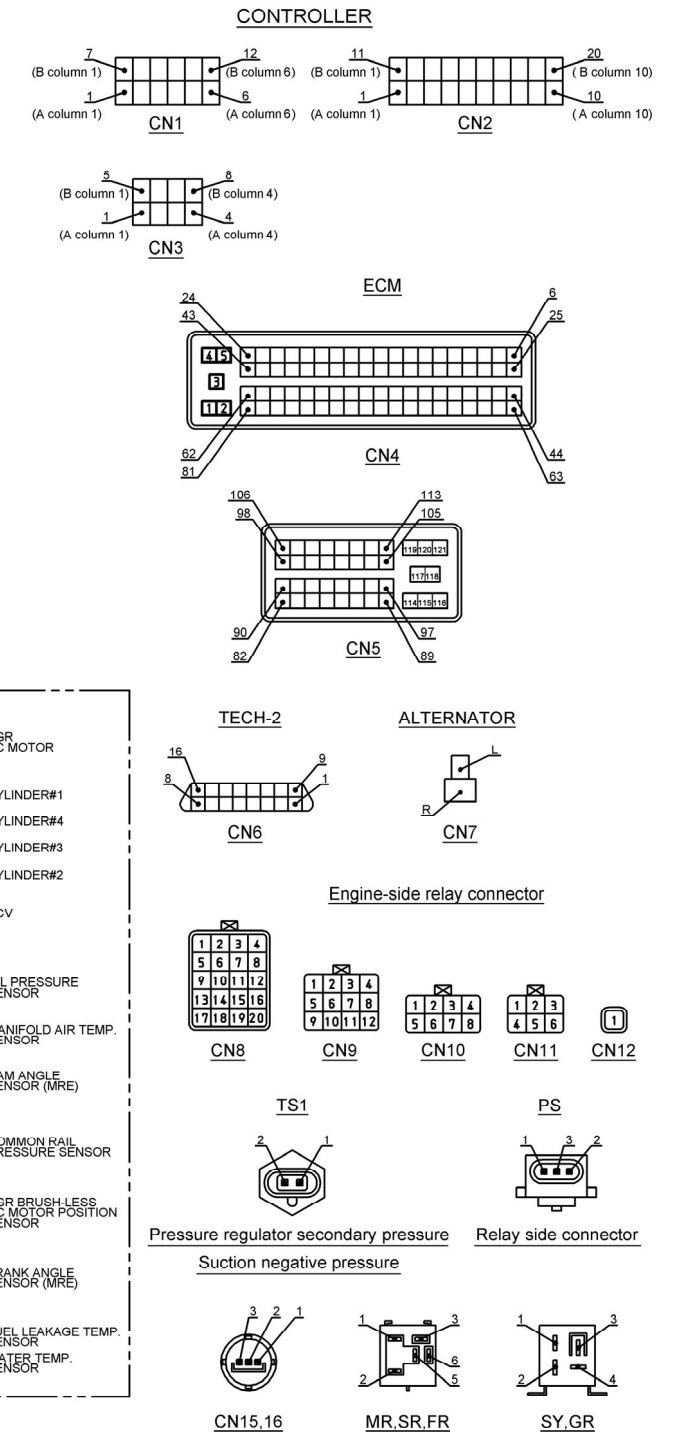

7. Specifications

7.4 Piping Diagram

7.4.1 Compression air · Compressor oil

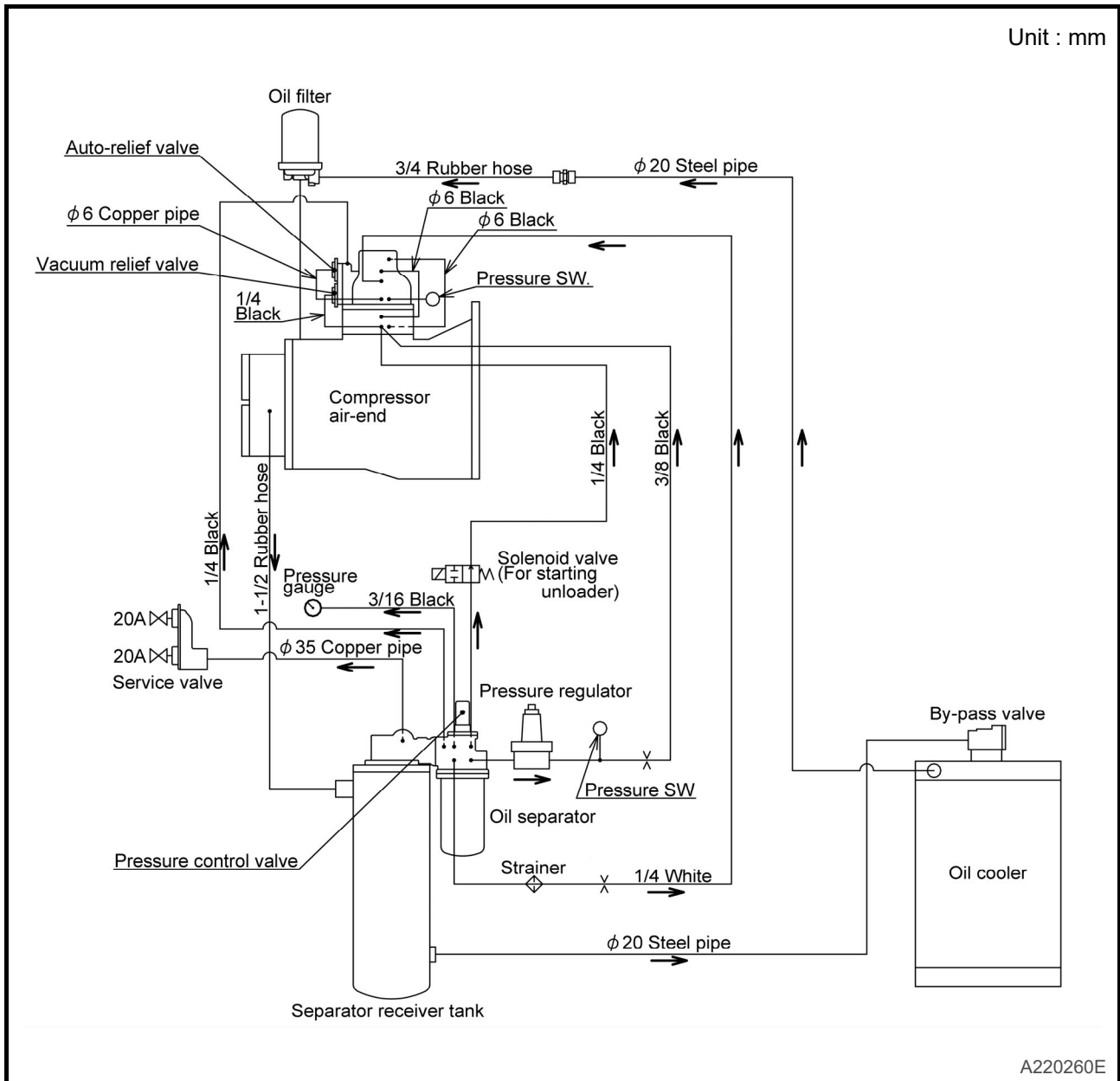

7. Specifications

7.4.2 Fuel Piping

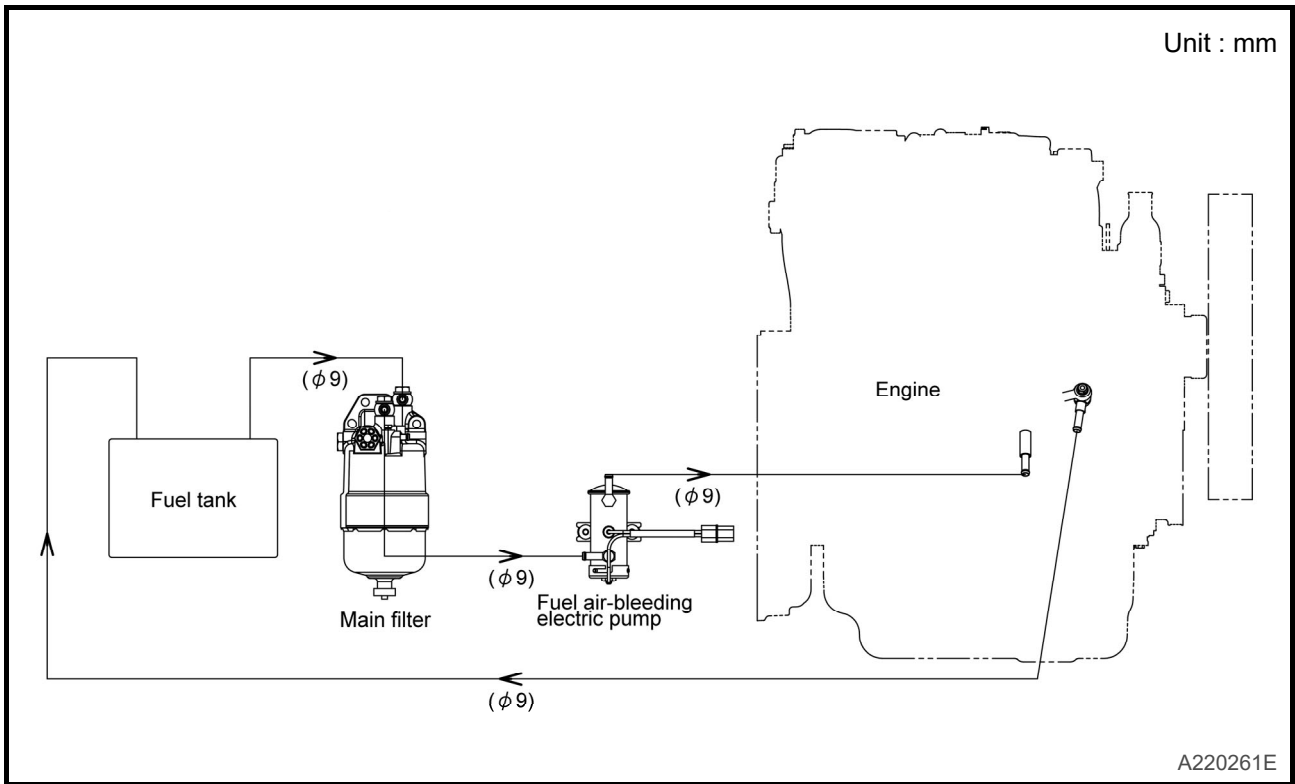

HOKUETSU INDUSTRIES CO., LTD.

8TH FLOOR SHINJUKU SAN-EI BLDG,
22-2 NISHI-SHINJUKU 1-CHOME, SHINJUKU-KU
TOKYO 160-0023 JAPAN
TEL:81-3-3348-7281
FAX:81-3-3348-7289
URL:<http://www.airman.co.jp>

Copyright (C) 2023 HOKUETSU INDUSTRIES CO., LTD. All Rights Reserved.

39600 28050

Printed OCT. 2023

AIRMAN
HOKUETSU INDUSTRIES CO., LTD.